

2019

AVANOS - ILGAZ - CANIK - TOROS - ZIGANA  
(ROASTER - SUPERNOVA - SAUNA - HAMMAM - STAR)



## SOLID FUEL HYDRO STOVE / COOKER USERGUIDE



TÜRK PATENT [ ] ENSTİTÜSÜ





# Contents

INTRODUCTION .....	4
1. IMPORTANT NOTICE .....	5
1.1. General Safety Warnings .....	5
1.2. Operating Warnings.....	6
2. TECHNICAL SPECIFICATIONS .....	6
3. FUEL SPECIFICATION .....	9
4. INSTALLATION.....	11
4.1. Operating Environment.....	11
4.2. Electrical Connections.....	12
4.3. Plumbing Connections .....	13
4.3.1. Plumbing Schema .....	15
4.3.2. Open Expansion Tank .....	17
4.3.3. Plumbing Water Specification.....	18
4.4. Ventilation And Air Flow.....	18
4.5. Chimney Instructions.....	19
4.6. Smoke Pipe Instructions .....	20
4.7. Suitable Shapes Of Chimney and Connections.....	21
5. OPERATING .....	23
5.1. Pre-Operation Warnings.....	23
5.2. Fuel Loading Process .....	23
5.3. Combustion Control.....	24
5.4. Initial Ignition .....	25

6. OVEN HANDLING AND COOKING INSTRUCTIONS .....	25
7. USED HARDWARES OF STOVE.....	27
7.1. Thermostat Use And Specifications .....	27
7.2. Use Of Mechanical Air Flap.....	28
7.3. Use Of Shaking Rods .....	29
7.3.1. Cleaning The Grat.....	29
7.3.2. Ash Eliminate .....	30
7.4. Use Of Smoke Flap (Star) .....	31
8. MAIN PARTS AND DIMENSIONS.....	32
9. PUMP WARNING LAMP .....	37
10. MAINTENANCE and CLEANING .....	38
11. PROBLEMS, CAUSES and SOLUTIONS.....	42
12. SIGNIFICIANT INSTRUCTIONS for EFFECTIVE USING.....	45
13. SUGGESTIONS and FEEDBACK.....	46
GARANTİ BELGESİ .....	<b>Hata! Yer işareti tanımlanmamış.</b>
GARANTİ ŞARTLARI.....	<b>Hata! Yer işareti tanımlanmamış.</b>
CERTIFICATE OF WARRANTY.....	47
WARRANTY CONDITIONS.....	48

# INTRODUCTION

*Dear Friend of İFYIL;*

*İFYIL TERMO İKLİMLENDİRME SAN. Ve TİC. LTD. ŞTİ. we manufacture the most efficient hydro stoves with utmost care for our distinguished customers. So, please read this userguide carefully before starting to use our stove and keep it as a reference in any case.*



## **Information**

This symbol high lightens the significant details for correct usage of stove. If the warnings are ignored, product will not be fully correct & regular and this can cause customer not satisfaction.



## **Attention**

This symbol high lightens the possible serious risks during operation of stove. So this user guide should be read carefully before using the stove and utmost attention should be paid to the warnings.

# 1. IMPORTANT NOTICE

## 1.1. General Safety Warnings

- Please, carefully read the manual to get the best yield from the stove
- The product should be installed in accordance with the legislation of the country in which it will be used and the necessary safety precautions should be taken. Otherwise IFYIL will not accept any responsibility.
- Any change on the stove should be done by authorized person.
- Spare parts should only be used by the recommended manufacturer.
- IFYIL hydro stoves must be installed according to the installation schema.
- During the burning of your stove, the outer surfaces of the stove (doors and glasses, exterior plates, stove base, etc.), heating surface (casting etc.), metal handles, pipes and the inside of the oven should be careful as it is hot.
- Definitely do not fire the stove while in the lack of water.
- Do not fill the water in the stove and the installation system by the safety valve.
- Should be fired the stove after the air is blown from the calorific stove and installation system.
- The chimney should be cleaned at least 2 times per year.
- Flammable materials should be kept away against the fire risk.
- Install the product in locations equipped with fire risk.
- Stove base (glass, ceramic, marble etc.) are recommended in Wood and laminate parquet floors for stoves.
- IFYIL stoves should not be installed in the places where people sleep. Stoves are recommended to be avoided in places where sleep.
- The stove should never be installed in the presence of flammable gases and materials.
- Never use flammable liquids and gases in the combustion chamber.
- The product should only be used as intended. Different uses cause hazards.
- The stove should not be operated when the lid is open or the glass is broken.
- Please comply with these rules if there are local rules or norms for the solid fuel chimney according to country regulations. If there are no local norms, must be comply with EN 13384-1.

## 1.2. Operating Warnings

- Assembly of İFYIL stoves and fireplaces; Electrical connections and installation should be done in accordance with the scheme.
- İFYIL stoves are suitable for home, office and interior. İFYIL stoves balcony, warehouse, bathroom etc. should not be installed in such areas.
- In domestic use, such as kitchen, living room, entrance hall; Use in places such as cafes, restaurants, workplaces.
- We do not accept any responsibility for any problem due to the outdoor installation of stove.
- İfyil stoves must not be installed into open, moisture, idle places etc.
- If the radiators are not heated, the system is checked for air. Radiators should be taken if there is air.
- The heat requirement of the place to be installed must be calculated and the appropriate stove selection must be made.
- Fuel should be checked if wet or not. Fuel should not be damp.
- The inside of the stove should not wash with water.
- If there is a fire in the chimney pipe, close the stove and contact the competent authorities.
- Periodically check the smoke outlet duct.
- If the product does not work properly, please turn it off.



**Customers not obeying the above requirements and schemas cannot claim any right for any problem. In any case, contact your dealer or İFYIL.**

## 2. TECHNICAL SPECIFICATIONS

This device should be installed in accordance with the related regulation and EU standards.

- ❖ EN 13240 - Roomheaters fired by solid fuel-Requirements and test methods.
- ❖ EN 12815 - Residential cookers fired by solid fuel - Requirements and test methods (Star)
- ❖ 2014 / 68 / EU – Pressure equipment directive

Technical Specifications			Measured Values				
Device type/model; Solid Fuel Hydro Stove			ROASTER	SUPERNOVA	SAUNA	HAMMAM	STAR
Nominal heat output	Wood	kW	20	29	20	20	23
	Briquette	kW	21	30	21	21	24
	Coal	kW	32	38	32	32	34,5
Water heating power	Wood	kW	16	25	16	16	18
	Briquette	kW	17	26	17	17	18
	Coal	kW	26	34	26	26	27
Space heating power	Wood	kW	4	4	4	4	5
	Briquette	kW	4	4	4	4	6
	Coal	kW	6	4	6	6	7,5
Efficiency		%	80	80	80	80	84,93
Fuel type			Wood, Briquette, Coal				
Fuel loading zone			Front loading		Top loading	Top-Front loading	
Primer burning air control			Half Automatic				
Seconder burning air control			Manual				
Permissible operating temperature	Maximum	°C	80				
	Minimum	°C	40				

Permissible maximum operating pressure		bar	2				
Test pressure		bar	4				
Boiler water volume		L	39	64	39	39	39
Recommended flue pipe draft		Pa	18				
Weight	Stove	kg	229	211	182	180	296
Dimensions (Width x Depth x Height)	Stove	mm	650x745x1146	650x745x1146	650x745x880	650x745x880	1158x733x924
	Oven	mm	320x480x175	-	-	-	367x495x260
Connections	Water round-trip connections	inch	1				
	Expansion tank connections	inch	3/4				
	Chimney connection	mm	Ø 130	Ø 130	Ø 130	Ø 130	Ø150
Electric Consumption		W	45	45	45	45	45
Electric connection		Vac/Hz.	230/50				
CO Emission for %13 O <sub>2</sub>		mg/m <sup>3</sup>	935,25	935,25	935,25	935,25	1477

### 3. FUEL SPECIFICATION

In order to achieve the maximum performance of IFYIL stoves; Calorific value and properties of the fuel to be used is very important. The calorific value of the fuel depends on the humidity and density. The tendency of the moist fuel to burn is low. The humidity in the fuel provides less heat as more energy is needed to evaporate. The yield / performance of the product may vary depending on the type of fuel used. Please observe the following when selecting / using the fuel. **Otherwise, IFYIL will not accept any responsibility for your problems related to heating and any faults that may occur.**

#### **For Wood:**

The wood logs to be used should have a moisture content of less than 20% and should be stored in a dry place. The use of damp wood, the soot can accumulate in the chimney and may cause the formation of fire.

Not all trees have the same characteristics. Drying time and calorific value vary according to the type of wood. Fresh (wet) wood is not suitable for combustion because it has a moisture content of about 60%. It is therefore recommended that fresh (wet) wood be dried in a dry and ventilated place for at least two years before use.



The wood from resinous trees creates a lot of soot, often requires more chimney and stove cleaning and can shorten the life of your device.



Continuous and long-term use of aromatic trees (eucalyptus, myrtle, etc.) will damage the grill portion of the product.

### **For Briquette;**

The briquettes to be used must have a moisture content of less than 12% and should be stored in a dry place. The use of damp briquettes may cause fire in the chimney due to accumulation of soot in the chimney.

### **For Coal;**

The coal to be used must have a moisture content of less than 20%, low ash content of less than 14% and a sulfur content of less than 1%. High levels of moisture and sulfur in coal content can cause sulfuric acid and serious damage to your stove. Caloric value of coal to be used should be at least 5000 - 7000 kcal / kg. Lemon-sized coal should be used for a good burning.

### **The following substances should not be used as fuel.**

- Moist / Wet fuels (Wood, Coal, Briquette)
- Contains high carbon materials.
- Painted wood.
- Hardboard wastes
- Waste materials (textile products, plastics, pouches, petroleum waste etc.)
- Flammable / combustible / flammable / explosive gases and liquids.
- Dust or hazelnut size type of coal.

**The boiler structure and mechanical parts may be damaged if used.**



**When there is no flame in the combustion chamber, a high amount of smoke may be generated when the fuel is loaded onto the embers; this may contain explosive gas-air mixture in the smoke content and may cause explosion risk.**

## 4. INSTALLATION

- This stoves product for houses, offices and internal places.
- İFYIL stove should not be installed in areas such as balconies, bathrooms, warehouses. In case of use outside of the interior, our company accepts no responsibility for the problems related to heating.
- There will be loss of energy and efficiency in balcony, warehouse or etc.

### 4.1. Operating Environment

- It is recommended to put stove base (glass, ceramic, marble etc.) on wooden and laminated parquet floors.
- The floor should be smooth and of quality to carry stove weight.
- Flammable products must be kept at a safe distance from the risk of fire.
- Install the product in locations equipped with fire risk.
- The product should be placed so that it can provide the air required its for combustion.
- The room volume 30 m<sup>3</sup> shall not be less than.
- When the stove installation is done, adjust the feet to ensure that the height of the base is 4 cm.
- The installation of the stoves should not be made to the places where people sleep.

#### ***Safety Minimum Distance***

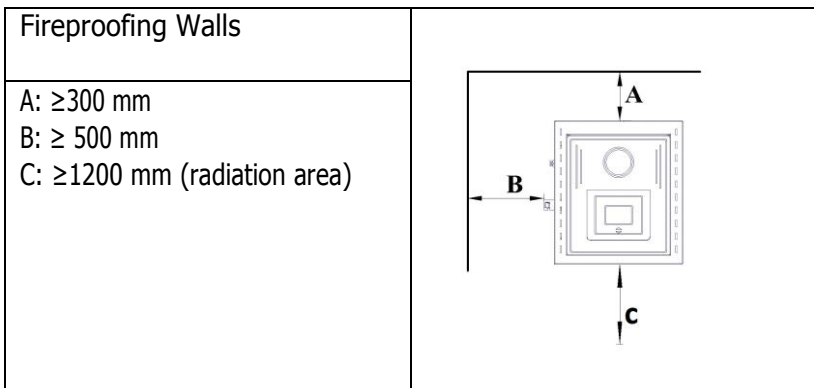

Figure - Safe Minimum Distance



**If the stove is installed next to flammable wall, isolation for the wall should be done.**

- If the base where the stove is to be installed is made of flammable materials. If the stove is put on flammable material, suitable isolation must be done.
- Please keep away heat sensitive materials from stove (flammable, explosive etc.).

## 4.2. Electrical Connections

First insert the power cable into the back of the stove, then insert the cable outlet. It is recommended to use a power supply against prolonged power outages.



A voltage regulator using is required in areas with voltage irregularities. Electronic and electronic card failures that may occur due to the absence of a voltage regulator are not covered by the warranty.



**Use your stove and running in a socket with ground.**

## DİJİTAL TERMOSTAT ELEKTRİK BAĞLANTI ŞEMASI (DIGITAL THERMOSTAT ELECTRICAL CONNECTION DIAGRAM)

- Kahverengi/Brown
- Mavi/Blue
- Sarı/Yellow
- Siyah/Black
- Kırmızı/Red

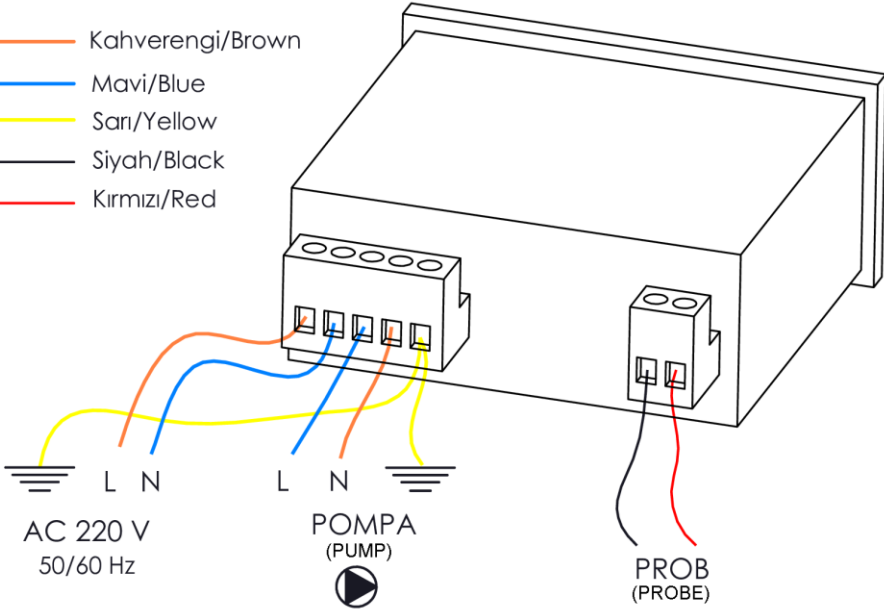

NOT: Elektrik enerjisini kesmeden müdahale etmeyiniz!

NOT: Danger! Disconnect electrical supply, before working on this equipment!

### 4.3. Plumbing Connections

- 120 cm and longer radiator must be connected to the installation with a reverse connection.
- Definitely should had fill and drain valve in the installation
- The safety valve is mounted on the body.
- Boiler lit (off) the water pressure should be in the range of 1-1,5 bar. Otherwise drain / refill valve should be checked.

- It is recommended to install a thermostatic valve in the radiators to ensure that the room temperature can be kept to the desired degree and to provide high comfort at low cost.
- EU standards. Half of the installation should be 1 " (32 boiler installations), half 3/4 " (25 installation booths). Only the radiator braggings should be 1/2" (20 tubes). (Recommended cross-section pipe, composite pipe, copper pipe, black iron pipe).
- Hydro boiler's connections must be made with conical iron union.
- It is recommended to install an air purifier in the expansion line. (Installation Schema)
- It is recommended to use anti-scale magnetic solvent in the exchanger and boiler for cold water inlet.
- You can add water to installation system by including an external filling valve in the return line of installation.
- The valve 11 in the installation diagram allows the water to be drained in the stove boiler and the installation.
- Water is reinforced by turning half a turn from the installation water filling valve.
- The heat safety valve valve (5) must be left open.
- The heat safety valve included in the product (Installation Scheme - 5 ) is activated automatically in the event of an unexpected heat increase (> 85'C). On the one hand, while providing hot water discharge inside the boiler, it also provides cold water to the boiler from the water line.
- Frost protection measures must be taken. (Antifreeze).
- There should be no sediment, dirt and undesirable solid particles within the water content to be applied to the boiler and the installation, and the drinking water quality installation water should be used.
- If necessary, a strainer and lime trap must be used in front of the water reinforcement pipes.
- No particle, dirt, lime or chemical additives should not be in the plumbing water to be used, aggressive waters of with corrosion should not be used.

### 4.3.1. Plumbing Schema

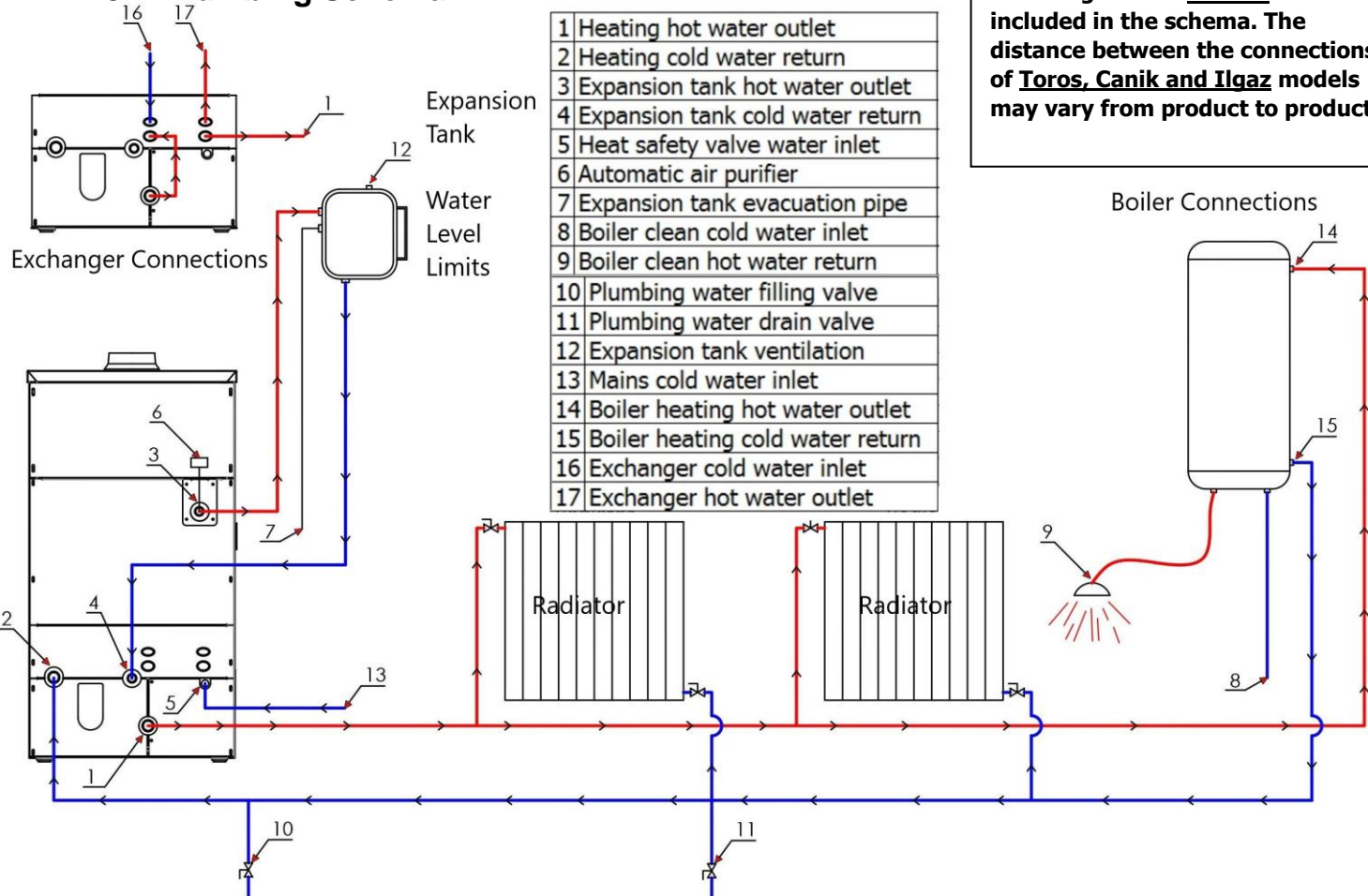

Model: Star

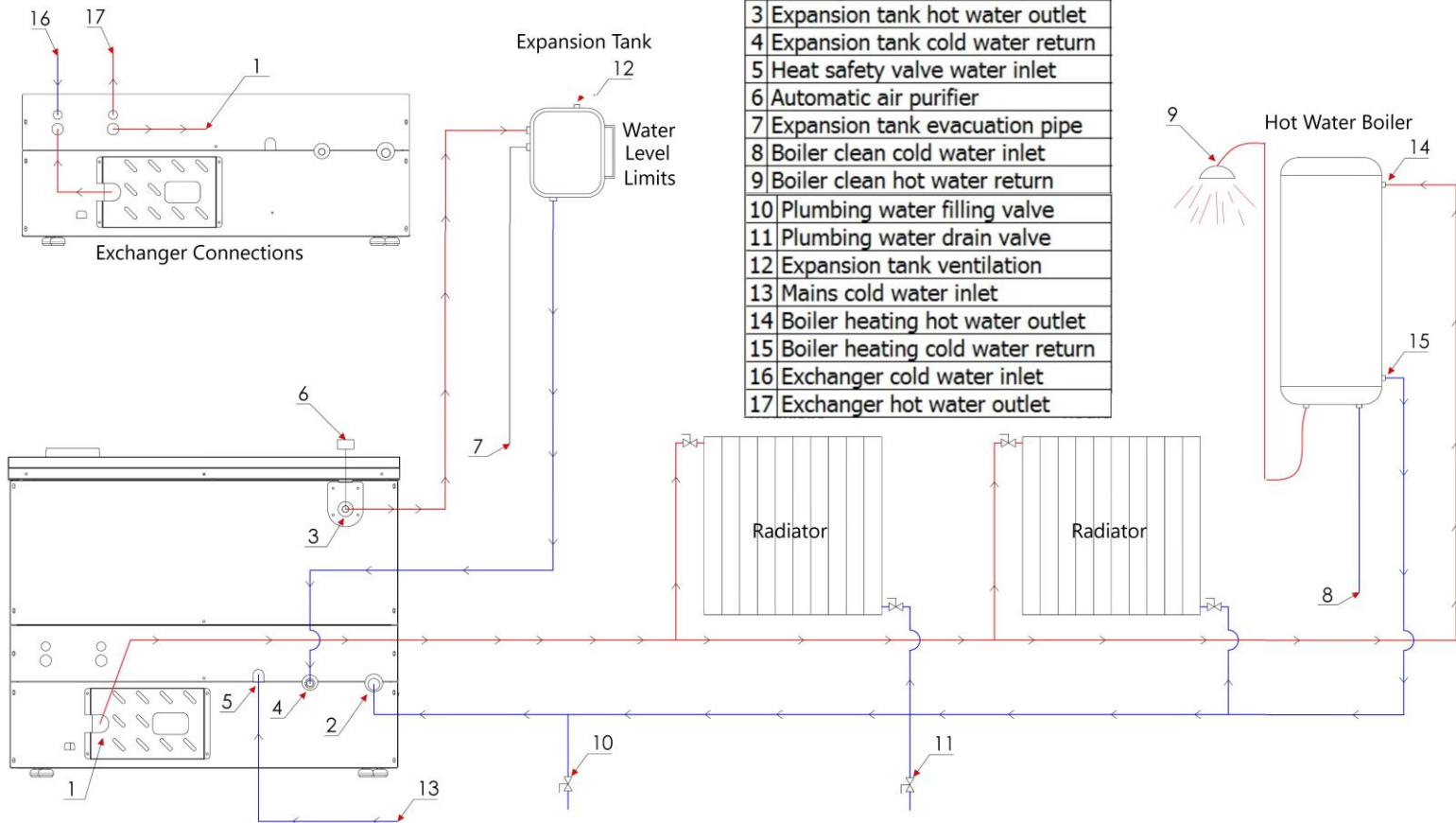

### 4.3.2. Open Expansion Tank

When water is heated from 10 °C to 90 °C, its volume increases by about 3.55%. The surplus water that is heated and expands in the boiler is collected in the expansion tank and the water of the installation is cooled and the level is completed from here. Expansion tanks prevent increasing the pressure of the system because of the expansion of the water in the installation.

In building heating systems, while providing the safety of the boiler and the installation, it completes the losses due to the evaporation of the water in the installation due to various leaks, repair and maintenance reasons.

In open expansion hot water heating system; it is essential that water is in direct contact with air and its temperature does not rise above 100 ° C. Water contact with air should not be obstructed.

- Expansion tank connections must be made according to the installation diagram.
- Installation of the open expansion tank must be done above the highest radiator (bath towel).
- The valve must not be used in the return and return lines of the expansion tank.
- The return and return pipes cannot be used less than ¾".
- Imbisat water drain line (valve no 7) should be given to water drain.
- In places where the air temperature is below 0 °C the expansion tank should be in the house. Reinforced antifreeze should be used in these regions.
- Water level of expansion tank should be checked once a week. If the water level of expansion tank appears to below half level, fill the water with filling valve.
- Safety pipes must be installed without any downsizing and always rising towards the expansion vessel.



It is mandatory to use open expansion tank in IFYIL solid fuel stove and cooker.

In these systems, closed expansion cannot be used.

**Otherwise, IFYIL will not accept any liability.**

### 4.3.3. Plumbing Water Specification

Properties that should be in boiler water; EN 12953-10 "Shell boilers- Part 10: Requirements for feedwater and boiler water quality" must comply with the standard. In the boiler and heating system, water in quality of drink water should be used in order to prevent damage caused by corrosion. Aggressive water should not be used for chemical additives because of corrosion. The water content to be filled in the boiler and the installation must not contain residues, dirt and undesirable solid particles. These deposits and dirt are extremely harmful to the circulation pump. If you are suspected that the water is not clean, necessary precautions should be taken.

Calcified water used in the system forms a lime and mud layer on the heating surfaces of the boiler. This lime and mud layer prevents water circulation and heat transfer and deforms the boiler. **This is not covered by the warranty.**

### 4.4. Ventilation And Air Flow

- In the room where the stove is installed, there should be enough air to allow regular combustion.
- The location of stove fresh air inlet must be provided.
- It is recommended that the stove should be connected to an environment (external environment) where the air suction pipe can be continuously flowing clean air with hermetic pipe.
- Use 300 cm<sup>2</sup> lower, 200 cm<sup>2</sup> upper orifice. These grilles should never be closed. Otherwise, it presents a great danger.
- Avoid installing the unit in the same environment with the following;
  - B type gas heaters or exhaust fan or fan less hoods
  - Collective ventilation pipes.
  - Aspirator device running in the same environment, can cause problems.

## 4.5. Chimney Instructions

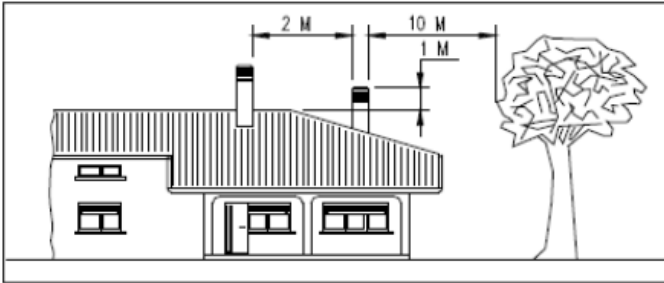

- The main cause of the chimney fire;
  - Improper selection or pipe that dust is flammable fuel.
  - In the event of appropriate conditions can cause fires ignite in the ducts.
- Ways of avoiding them;
  - The chimney should be cleaned at least 2 times per year, depending on the fuel quality.
  - Correct and appropriate chimney selection should be made.
  - Ensuring that the sealing and smoke in the chimney pipe and must be made in isolation.
  - After installation, chimney cleaning must be done before ignition operation.
  - In case of a re-ignition after prolonged period of time, the smoke paths and flue congestion must be checked.
  - Surrounding the peak point of the roof of the chimney to the interference of the obstacle (the ridge) from height must be at least 80 cm.
  - Stove is not suitable for a shared chimney system.
  - There should be no cracks on the flue to prevent the flue gas from leaking. The inner surface of the chimney should be smooth.
  - Should chimney's pipe inner diameter is 130 mm. (For star 150mm)
  - Chimney flue test should be performed before making connections. If the chimney connections should be carried out after removal of the traction problem had this problem in the chimney.
  - The stove pipe connected to the horizontal flue pipe must not be longer than 2m. It is recommended to use 45<sup>o</sup> elbows in chimney pipes instead of 90<sup>o</sup> bend. (Site selection for stoves should be determined by the closest point where the chimney.)
  - To avoid turbulence around the chimney flue without any obstructions (high buildings, trees, etc.) Must be at least 10 m away.

- Chimney cap should be used to prevent the flow into the chimney flue repercussions of windy weather and rain.
- Concrete blocks are affected by temperature changes, concrete flat roof which is in direct contact with the air must be absolutely isolated.
- Chimney cleaning cap should be under the flue pipe, chimney cleaning should be done here.
- An accurate and sufficient flue system for smoke extraction (a chimney with natural traction that does not backfire in the event of a power outage.) is necessary.
- Necessary precautions should be taken to prevent condensate formed in the chimney from reaching the boiler.
- Clogging or closing of the flue outlet poses a great danger.



**Stoves must be connected to a chimney duct which can move vertically smoke outside the building or its flue pipe to the highest point of the building. Chimney connections, if that would be considered illegal in the first combustion fumes can cause the wall to infiltrate the processing of these leaks may leave traces. Leaked smoke and / or flames can cause burns or fire because it can be very hot.**

## 4.6. Smoke Pipe Instructions

- Smoke pipe connections are very important; therefore, it must be done carefully.
- The connections of smoke pipes must be made according to the guarantee conditions.
- The minimum safety opening surface sections should be 15%. Slope in the horizontal section of the pipe should be 3-5%. (3-5 cm per meter). The horizontal chimney's duct should not be longer than 2 m.
- The stove chimney pipe inner diameter is 130 mm (For star 150mm).
- Smoke pipe should be made of durable materials for heat, corrosion and condensation.
- The stove pipe should not be extended by piercing the window or wall to prevent the smoke gas from getting warmer and quieter.

- Please take care of flue pipe standard's sizes, the problems in case of using nonstandard sizes will not be under our responsibility.
- Sediment formation in chimneys causes the chimney diameter to decrease and the combustion efficiency in the stove decreases. The pipes and flue must be cleaned before the stove is installed.

### 4.7. Suitable Shapes Of Chimney and Connections

The remaining section of the chimney outside the home, it must be insulated. The smoke in the event of an electrical failure of your stove with a natural drive capable throw out the chimney must be applied.

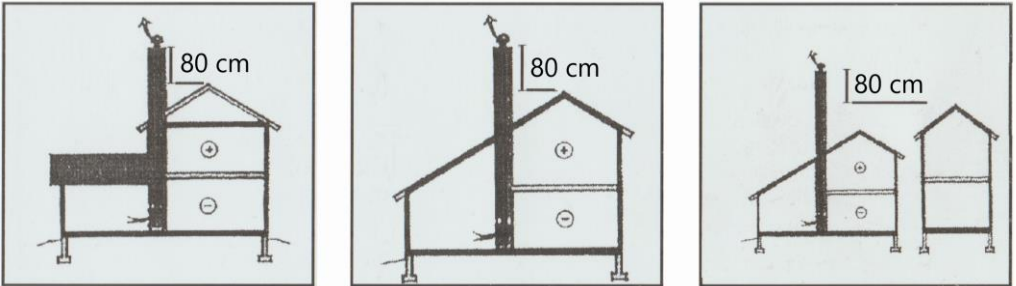

*Figure 3- Suitable chimney shapes*

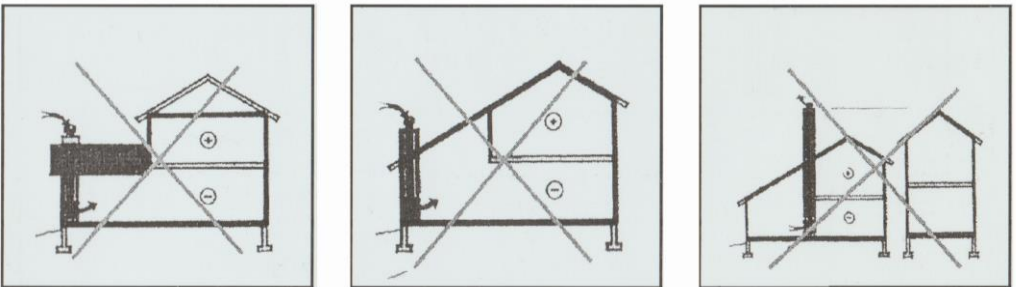

*Figure 4- Improper chimney shapes*

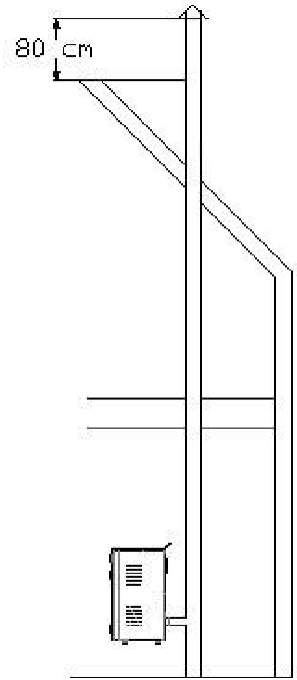
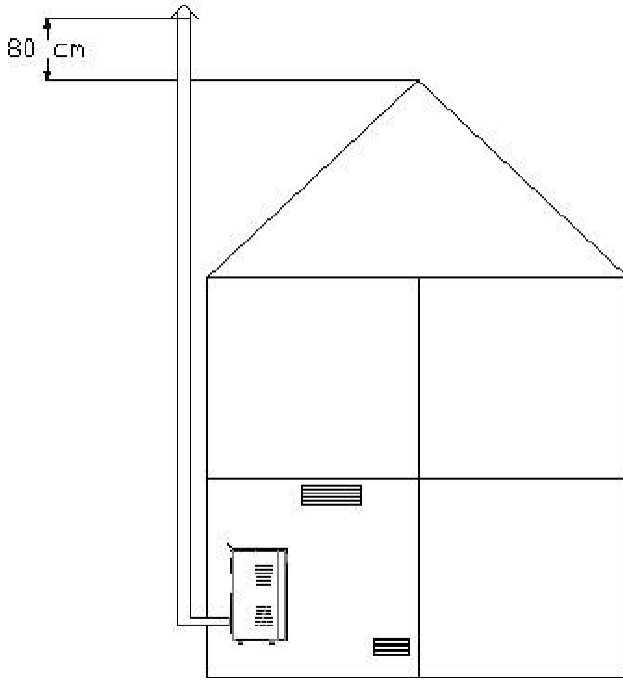

\*\*stoves shown in Suitable and unsuitable chimney shapes pictures are representation



HOUSES AND OFFICES NOT OBEYING THE ABOVE MENTIONED STANDARDS ARE POTENTIAL FOR FIRE AT ANYTIME AND CARBON MONOXIDE (CO) GAS LEAKAGE. **PLEASE FOLLOW THE ABOVE MENTIONED INSTRUCTIONS!**



**CLIENT ACCEPTS THAT; SUCH MANUFACTURER DOES NOT HAVE ANY RESPONSIBILITY IN ANY POSSIBLE DAMAGES**

**CLIENT NOT FULFILLING ABOVE MENTIONED REQUIREMENTS IN SCHEMAS CANNOT CLAIM ANY RIGHT OR COMPENSATION.**

## 5. OPERATING

### 5.1. Pre-Operation Warnings

- Water level of expansion tank should be checked once a week. Water level of expansion tank appears half level before burning
- Chimney and pipe connections must be checked for clogging and leakage.
- Combustion chamber, ashpit and air intake must be cleaned.
- Fuel should be checked if wet or not.
- After a long period of inactivity, check the required flue and pipe connections and the plumbing and freezing before using the appliance. If necessary, make repairs.
- The heater must be used when the outside temperature drops to + 12°C and below. If the outside temperature is between +12 and +15 °C, it should be limited. If the outside air temperature is above +15 °C, the heater must not be used. This information is a reference. Local governance provisions apply to the use of heating stoves.



**For warning labels affixed on the stove, remove before burning stove.**

**During the first burning stove clean room air intake must be provided.**



**The smoke and odor of the protective paint on the stove during the first combustion is short term, in this case open the doors and windows.**

### 5.2. Fuel Loading Process

The stove is suitable for intermittent combustion and continuous combustion. Fuel loading process must be applied for preferred combustion.

**Intermittent combustion;** fueling the stove regular intervals to maintain the continuous and efficient combustion of the stove. Depending on the burning of the fuel, intermediate loads should be made to stove. Before each fuel load, ash

cleaning is carried out with the swinging rod located on the right side of the stove to increase the efficiency and it is ensured that the fuel to be loaded is better to burn by taking in the air. Flared burning allows continuity of burning. This type of combustion is the recommended combustion mode to achieve more efficient combustion.

**Continuous combustion;** has the opportunity to burn for a longer period than the intermittent burn. In this combustion mode, the fuel is loaded without exceeding the maximum loading capacity of the stove. When this combustion is preferred, long-term combustion is performed depending on the fuel charged. In order to increase the efficiency, ash cleaning is done with the swinging rod beside the stoves, and it is ensured that the fuel gets better by burning.

**Ashing process;** it must be cold (not burning). The surfaces of the combustion chamber must be cleaned with the help of a cleaning brush before ashing. The swinging rod on the side of the stove is removed from the pit and turned to the right to empty the slag and ash. Before the cleaned ashtray is placed in the stove, the slag and ash poured into the ashtray chamber and into the mechanical air flap tanks are cleaned.

The stove maximum fuel fill height 15 cm.

Fuel ;

- Wood or briquette fuel fill quantity must be set for fuel type.
- Coal fuel filling period must be set option (intermittent or continuous) for combustion.
- Various solid fuels usable in this product. (Coal, wood etc.)

### 5.3. Combustion Control

The fireplace and ashtray cover should be kept closed except for ash emptying to prevent ignition, refueling and spreading of the soot.

- Combustion air intake is controlled by mechanical flap. In addition, thanks to the shaking arm, the ash is cleaned and the passage of the combustion air to the combustion chamber is facilitated.
- Primary air intake is provided by a mechanical air trap located behind the sole for the initiation and continuity of the burn.
- Secondary air intake is located at the top and bottom of the fireplace cover. During secondary combustion, the unburned gas generated in the hopper burns to reduce the emission values.

## 5.4. Initial Ignition

- You can follow the following sequence while igniting;
- Make sure that the combustion chamber, ashtray and ashtray tank are clean.
- Sufficient amount of coal is placed in the combustion chamber.
- First ignition is provided in the stove with easy burning wood pieces and / or paper.
- According to the preferred combustion mode (continuous / intermittent) fuel loading must be done.

# 6. OVEN HANDLING AND COOKING INSTRUCTIONS

## Model: Roaster / Star

- Oven interior measurements 320X480X175 (Roaster), 367x495x260 (Star) mm.
- Oven temperature can not be adjusted.
- Oven temperature and cooking time may vary depending on fuel type.
- Smell for a few hours during first use. This situation is normal. It is sufficient to provide ventilation. Do not breathe this smell.
- Regularly clean the appliance to ensure efficient use of the oven.
- The desired temperature must be reached before the oven is used.
- Keep the oven door closed.
- Do not heat the closed tin cans and glass jars.

- Do not put oven tray on the base. Heat can damage the bottom of the oven.
- Do not use the product with the oven door window removed or broken.
- When the food is placed in the oven the temperature may drop by about 20-30 degrees.
- It is recommended to rotate the baking tray or food periodically to ensure a homogeneous cooking of the food in the oven.
- Use suitable metal plates, aluminum and / or chrome containers with non-stick coating.
- Place the cookware in the middle of the oven when baking in the oven.



**Hot surfaces cause burns! The product will be hot while the stove operating. Do not touch hot surfaces (Oven glass, oven interior surfaces etc.). Keep away the children from hot surfaces.**



**Should be use oven heat resistant glove While put meal inside of oven.**



**Stay away from the oven door as steam may come out. The resulting steam may harm the user. Be careful. Before you remove the oven chamber for your safety, let the oven door open slightly so that the steam is removed and secondly the cover is fully open. Then open the oven door and remove the ovenware.**

## 7. USED HARDWARES OF STOVE

### 7.1. Thermostat Use And Specifications

<b><u>Thermostat specification;</u></b>			
Tolerance :	%	±1	
Operating Interval :	°C	0-120	
Storage Temperature Range :	°C	(-40) - (125)	
Long-term deviation :	°C / year	<0.04	
Dimensions :	mm	65x33x74	

#### Thermostat to adjust the operating temperature in the stove;

- First cut off electricity.
- Turn the power cord back on while the thermostat adjustment button is pressed.
- You can set the flashing temperature value on the thermostat display by pressing the button.
- Remember that the value you set is the temperature at which the pump starts operating.



**This setting is not for adjusting the water temperature in the stove.  
The circulation pump is for operating temperature setting.**

#### If you see "err" on thermostat screen;

- The temperature probe indicates that the probe is faulty or has a fault in the cable connection.
- If there is a " err " error on the screen, the pump will run continuously. This situation was created for the safety of your stove.
- In the event that the temperature error in the temperature probe is removed, the error is cleared and the thermostat normally continues to operate at the set temperature.

## 7.2. Use Of Mechanical Air Flap



- The air flap of the stove works at 40-80°C.
- By adjusting the air flap to the right of the stove you can adjust the water temperature in the specified range to determine the maximum temperature at which the stove will go to sleep mode.
- When the water temperature reaches the manually set value, the air closure closes to prevent air ingress and switches to sleep mode without a heater.
- When your stove is in sleep mode, when the water temperature falls below the value you have set, the air flap is automatically opened to allow your stove to catch air and start burning.

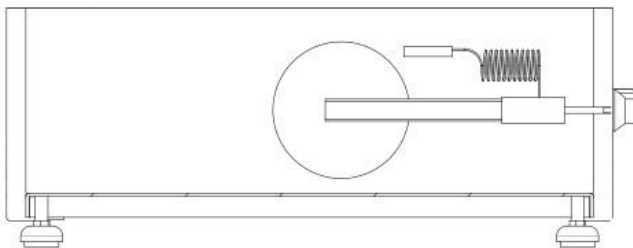

## 7.3. Use Of Shaking Rods

### 7.3.1. Cleaning The Grate

Model: Roaster / Supernova / Sauna / Hammam

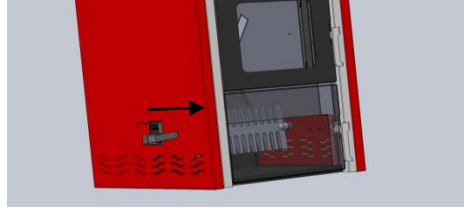
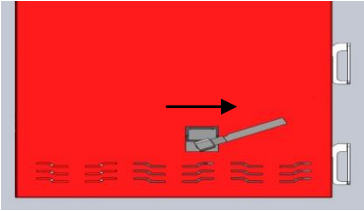

The shaking rod on the left side of the stove is removed from the placed position and pulled to the right to the horizontal position. The fuel in the form of ash and ashes on the grate is discharged to the ash pit.

Model: Star

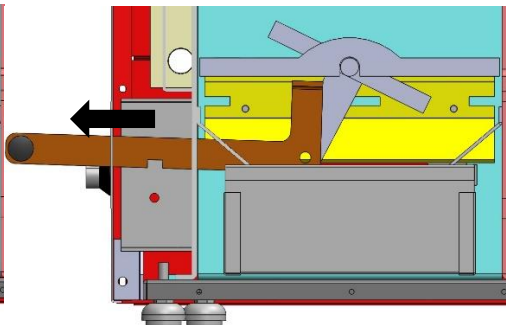
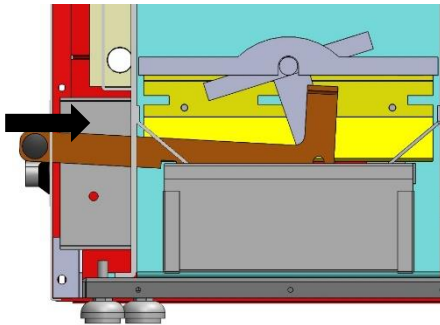

The shaking rods located next to the stove is lifted upwards (removed from the channel) and moved back and forth to ensure that ash and embers on the grill are poured into the ashtray. At the end of this process, the shaking rods should be horizontally (lowered) in the channel.

This process;

- Clean the combustion chamber before the stove is burned and ensure efficient combustion,
- After an unexpected water boil,
- After the burning in the stove is completed, it is done with the purpose of cleaning the stove.

## 7.3.2. Ash Eliminate

Model: Roaster / Supernova / Sauna / Hammam

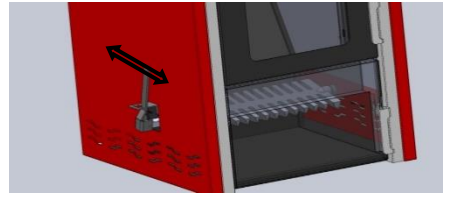
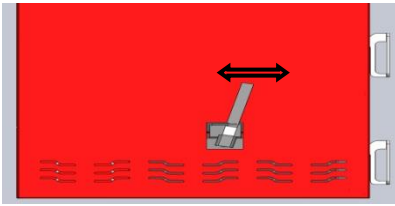

The shaking rod on the left side of the stove is not removed from the placed position and pulled to the right to the horizontal position. The fuel in the form of ash on the grate is discharged to the ash pit.

Model: Star

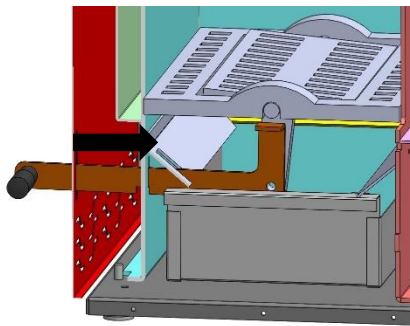
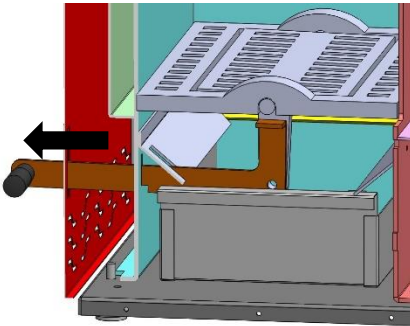

The shaking rods next to the stove is moved back and forth without lifting it up (horizontally and in the channel), and the ash on the grid is poured into the ashtray. During this process and at the end of the process, the shaking rods must be horizontally in the channel.

This process;

- Providing efficient combustion by shaking on the casting during combustion,
- Solid fuel (coal, wood, etc.) is made by burning air when it is made during combustion with the aim of providing more efficient combustion.

## 7.4. Use Of Smoke Flap (Star)

Smoke flaps in the stove during the discharge of the smoke generated as a result of firing by changing the way to achieve different functions, the curtains to provide the closure of the smoke paths. The smoke flap lever position for each function is shown below.

### **In the case of Initial Ignition or Fuel Loading;**

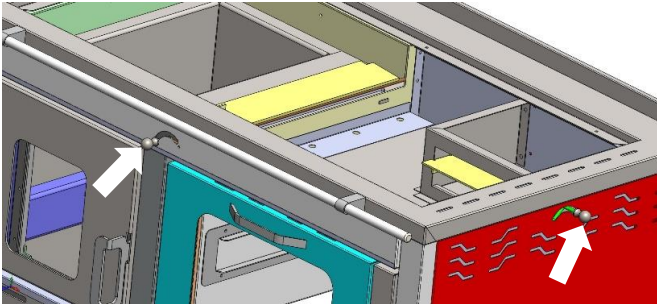

### **For Radiator Use;**

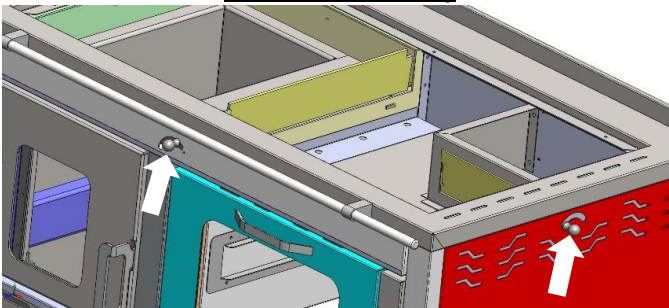

### **For Oven Use;**

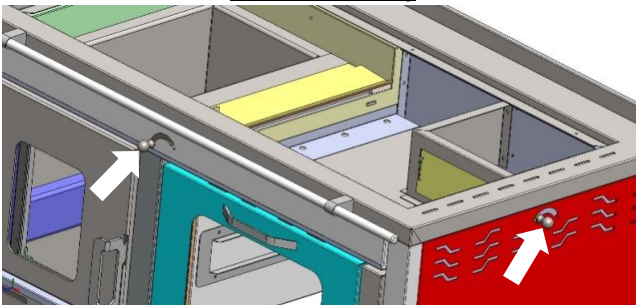

# 8. MAIN PARTS AND DIMENSIONS

## ROASTER

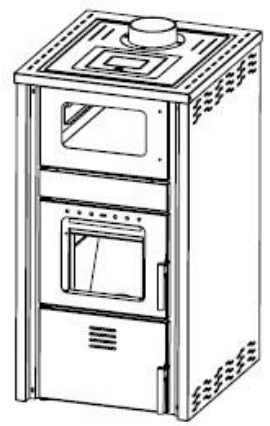
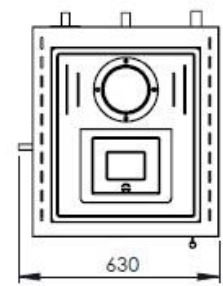
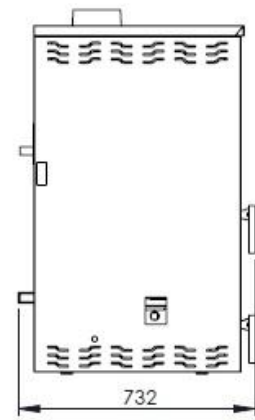
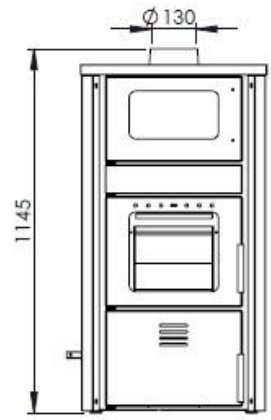
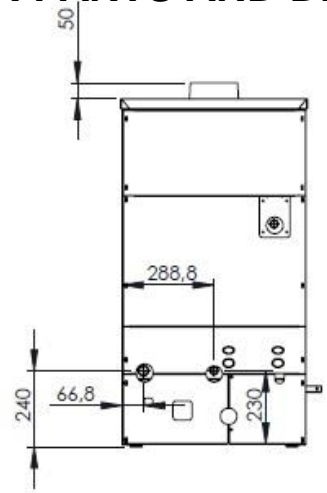



# SUPERNOVA

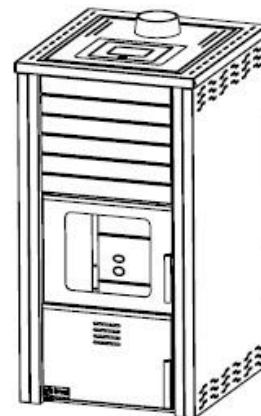
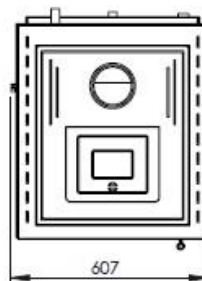
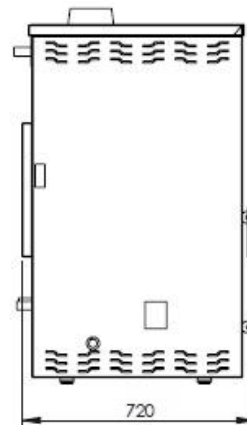
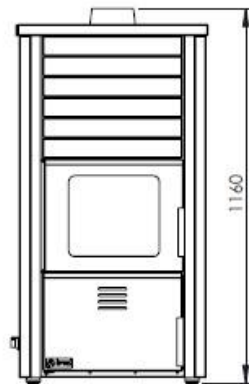
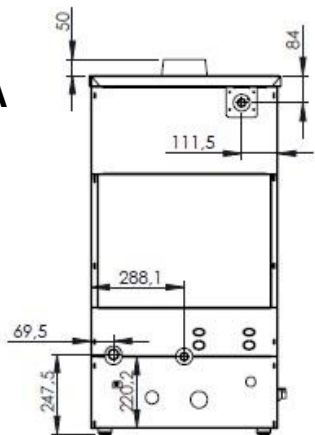

# SAUNA

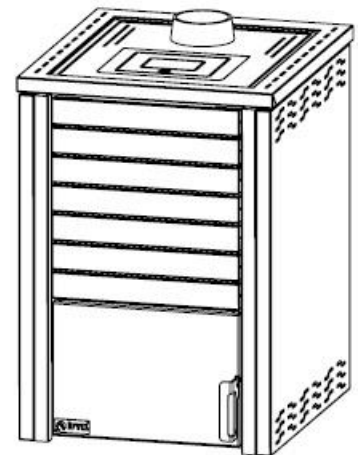
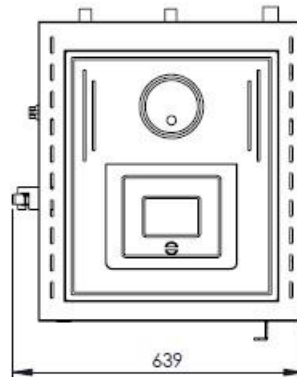
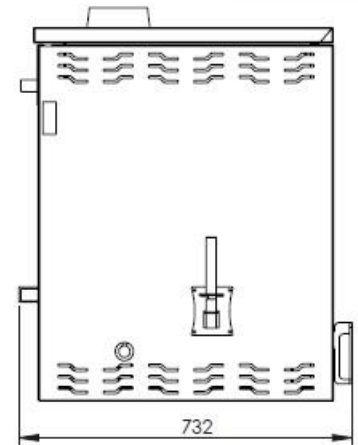
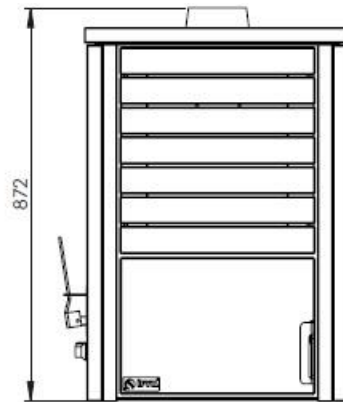
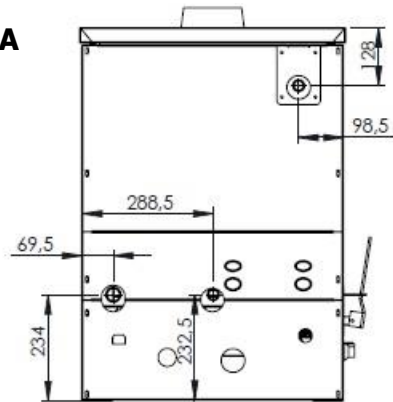



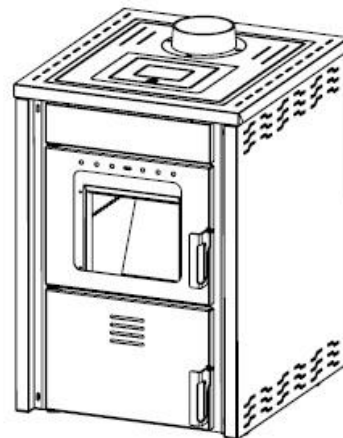
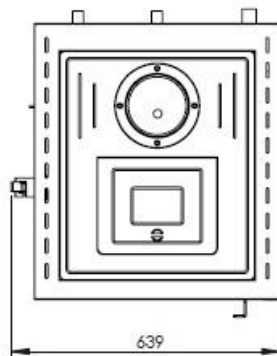
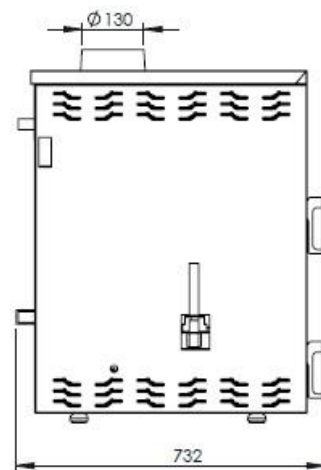
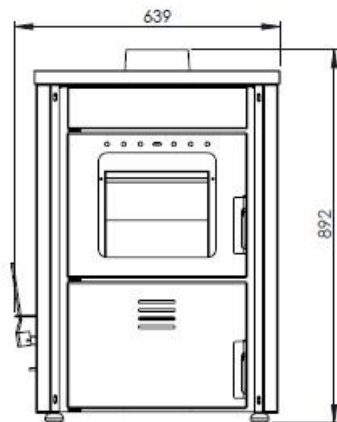
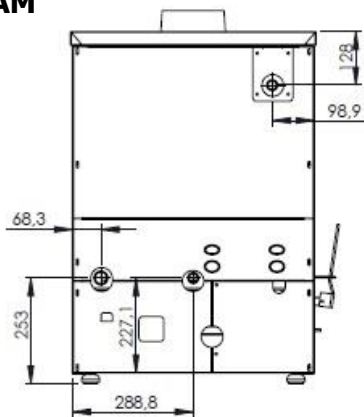

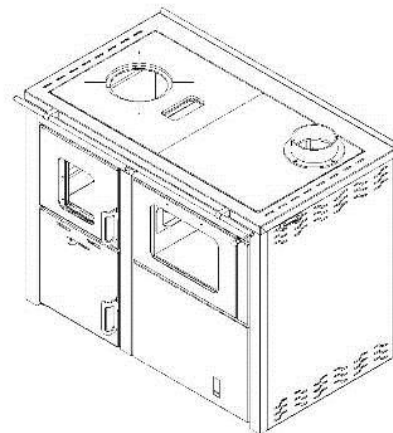
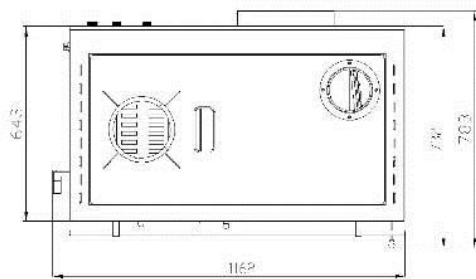
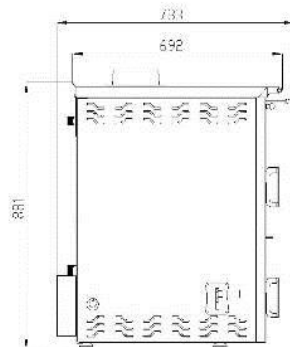
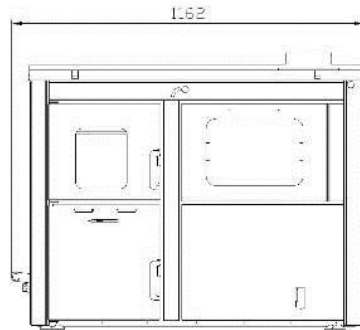
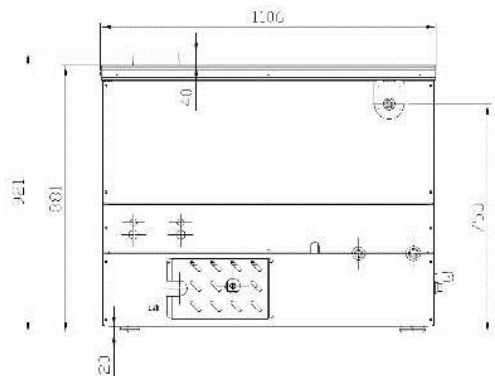

## HAMMAM



# STAR



## 9. PUMP WARNING LAMP

LED COLOUR	MEAN	DETAILED DESCRIPTION
 <p>Solid Green Light</p>	<p>Normal Operation</p>	<p>The pump is operating normally.</p>
 <p>Flashing Green Operation</p>	 <p>Air discharged The pump is standby mode (PWM version)</p>	<p>Pump will try to take the air in the system for 10 minutes. The pump then this process will not work if the maximum speed; by the user via the switch should be set to the desired value. The pump is in standby mode. (PWM version)</p>
 <p>Flashing red/green light</p>	<p>Unusual work (Pump is stop)</p>	<p>The pump has stopped because of the problem. After eliminating the problem, pump self again It starts operating.</p>
 <p>Flashing Red Light</p>	<p>Pump is stop.</p>	<p>By turning the pump Start again. if After rebooting the still flashing red If you see light; replace pump with a new one</p>
 <p>No Light</p>	<p>There is no power supply</p>	<p>Energy is not going to pump.</p>

## 10. MAINTENANCE and CLEANING



**All cleaning of your stove, while your stove is not lit (when cold case) and make the electrical connection closed position.**

### ROASTER

- Please take out top cast part (1) and clean surface with help of brush provided with stove.
- Top surface of heating compartment should be cleaned by taking out the top cast part (1) and sides should be cleaned with the brush.
- The surface inside the front loading door (2) should be cleaned with cleaning brush.
- Please clean both sides of grate (3).
- Please clean the ashbox (4) and ash room (5) regularly and pay attention to the ashes not to fall from ashbox. Otherwise mechanical air flow regulator will not work properly.
- Please clean the stove glass (6) with cream surface cleaner and side covers with wet cloth.
- When cleaning your stove, please do not use flammable, explosive etc. chemicals for cleaning.

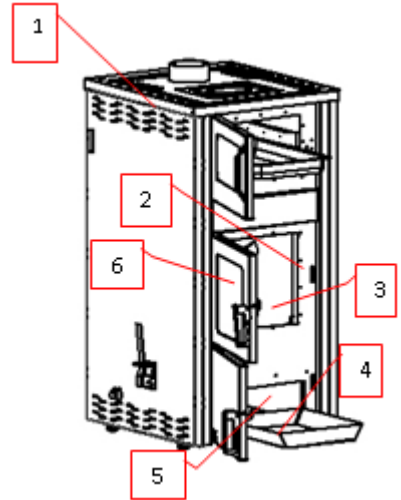

## SUPERNOVA

- Please take out top cast part (1) and clean surface with help of brush provided with stove.
- The surface inside the upper door (1) should be cleaned with cleaning brush.
- The surface inside the front door (2) should be cleaned with cleaning brush.
- Please clean both sides of grate (3).
- Please clean the ashbox (4) and ash room (5) regularly and pay attention to the ashes not to fall from ashbox. Otherwise mechanical air flow regulator will not work properly
- Please clean the stove glass (6) with cream surface cleaner and side covers with wet cloth.
- When cleaning your stove, please do not use flammable, explosive etc. chemicals for cleaning.

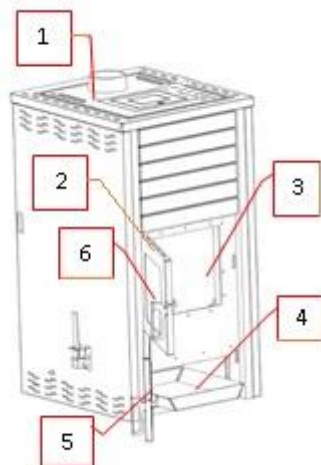

## SAUNA

- Please take out top cast part (1) and clean surface with help of brush provided with stove.
- The surface inside the upper loading door (1) should be cleaned with cleaning brush.
- Please clean the ashbox (3) regularly and pay attention to the ashes not to fall from ashbox. Otherwise mechanical air flow regulator will not work properly.
- Please clean both sides of grate.
- Please do not use flammable, explosive etc. chemicals for cleaning.

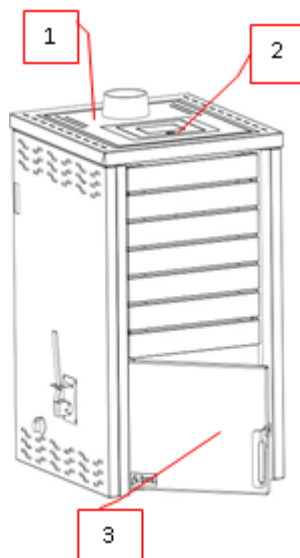

## HAMMAM

- Please take out top cast part (1) and clean surface with help of brush provided with stove.
- The surface inside the upper door (2) should be cleaned with cleaning brush.
- Please clean both sides of grate (3).
- Please clean the ashbox (4) and ash room (5) regularly and pay attention to the ashes not to fall from ashbox. Otherwise mechanical air flow regulator will not work properly.
- Please clean the stove glass (6) with cream surface cleaner and side covers with wet cloth.
- Please do not use flammable, explosive etc. chemicals for cleaning.

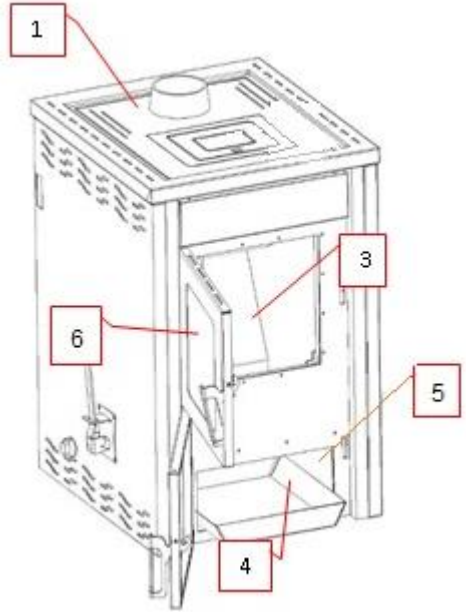

- The stove should be cleaned at least 2 times per year according to the type of fuel used.
- Do not spray cleaner on painted parts or on fire gate seals.

## STAR

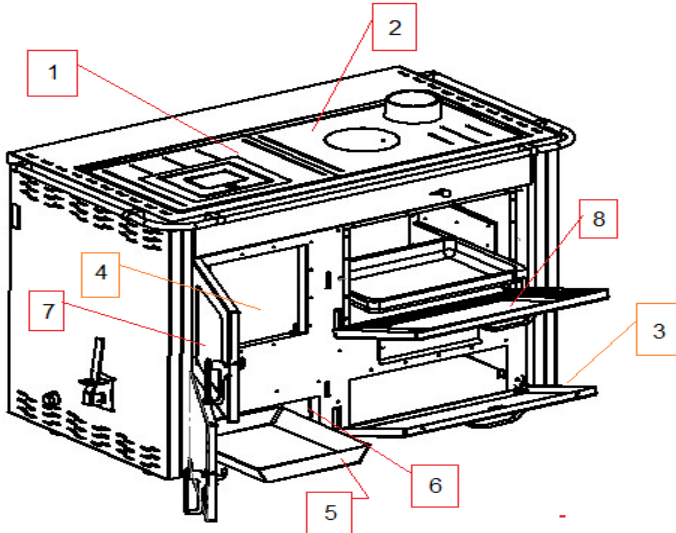

- Areas that appear when the boot lid (1) is opened must be cleaned with the help of a cleaning brush.
- The flue outlet should be cleaned with the help of a cleaning brush by lifting the upper casting (2) of the furnace.
- The upper mold (2) of the furnace should be lifted and the top and sides of the furnace should be cleaned with the help of a cleaning brush.
- The ash cleaning chamber (3) should be cleaned with a cleaning brush once a month by removing the screws.
- Clean the bottom and top of the right-left fixed and medium-moving grill in the combustion chamber (4).
- The ashbox (5) and ash room (6) of the stove must be cleaned regularly and care must be taken not to overflow the pheasant. Otherwise, the mechanical airbag will not be able to fulfill its mission perfectly.
- Clean the stove room (7) and the oven glass (8) with a damp, soft cloth using a surface cleaner and the outside with a damp cloth.
- Do not spray cleaning spray painted parts or on the gaskets on the fire door.
- Do not use flammable, explosive etc. when cleaning the stove. Do not use chemicals that could create a hazard.

## 11. PROBLEMS, CAUSES and SOLUTIONS

PROBLEM POSSIBLE	CAUSE	SOLUTIONS
<ul style="list-style-type: none"> <li>• <b>There is inefficient combustion and when the loading door is opened the flames are pointing outwards. (The flames are off the loading door.)</b></li> </ul>	<ul style="list-style-type: none"> <li>• Inadequate air combustion</li> </ul>	<ul style="list-style-type: none"> <li>• Maintain and clean the chimney.</li> </ul>
	<ul style="list-style-type: none"> <li>• Inadequate chimney draught</li> </ul>	<ul style="list-style-type: none"> <li>• A new chimney suitable for the needs of the system is required. Please read the relevant chapter in the manual for chimney details.</li> </ul>
	<ul style="list-style-type: none"> <li>• Improper fuel use</li> </ul>	<ul style="list-style-type: none"> <li>• Pay attention to the calorie and characteristics of the fuel you are using. For efficient combustion we recommend using dry wood or lemon charcoal.</li> </ul>
	<ul style="list-style-type: none"> <li>• Congestion in air passageways</li> </ul>	<ul style="list-style-type: none"> <li>• Providing fresh air to the room where the stove is located</li> </ul>
<ul style="list-style-type: none"> <li>• <b>The stove is not heating</b></li> </ul>	<ul style="list-style-type: none"> <li>• Installation failure</li> </ul>	<ul style="list-style-type: none"> <li>• Installation should be made in accordance with the installation requirements.</li> </ul>
	<ul style="list-style-type: none"> <li>• Improper fuel use</li> </ul>	<ul style="list-style-type: none"> <li>• Use fuels recommended by our company as fuel.</li> </ul>
	<ul style="list-style-type: none"> <li>• Capacity inadequacy</li> </ul>	<ul style="list-style-type: none"> <li>• The fuel used must be changed and sufficient fuel must be used.</li> </ul>
	<ul style="list-style-type: none"> <li>• Air in the heating installation</li> </ul>	<ul style="list-style-type: none"> <li>• The air in the installation must be taken.</li> </ul>
	<ul style="list-style-type: none"> <li>• Less fuel</li> </ul>	<ul style="list-style-type: none"> <li>• The insulation of the space should be improved.</li> </ul>

	<ul style="list-style-type: none"> <li>• Incorrect chimney selection</li> </ul>	<ul style="list-style-type: none"> <li>• The household heat needs to be checked and, if necessary, a suitable stove should be selected.</li> </ul>
	<ul style="list-style-type: none"> <li>• Isolation of the room used is not good</li> </ul>	
	<ul style="list-style-type: none"> <li>• Wrong product selection</li> </ul>	
<ul style="list-style-type: none"> <li>• <b>Even though the boiler is burning, it does not reach the desired temperature and the fuel consumption is high.</b></li> </ul>	<ul style="list-style-type: none"> <li>• Poor fuel usage</li> </ul>	<ul style="list-style-type: none"> <li>• Change fuel.</li> </ul>
	<ul style="list-style-type: none"> <li>• Not maintained and cleaned of stove.</li> </ul>	<ul style="list-style-type: none"> <li>• Stove should be done maintenance and cleaning.</li> </ul>
	<ul style="list-style-type: none"> <li>• The stove is getting air from under the top casting or from the covers.</li> </ul>	<ul style="list-style-type: none"> <li>• Call the technical service.</li> </ul>
	<ul style="list-style-type: none"> <li>• Inadequate chimney draft</li> </ul>	<ul style="list-style-type: none"> <li>• Stove should be isolated</li> </ul>
		<ul style="list-style-type: none"> <li>• Chimney construction is necessary for the installation of the chimney.</li> </ul>
<ul style="list-style-type: none"> <li>• <b>Consumes a lot of fuel</b></li> </ul>	<ul style="list-style-type: none"> <li>• Capacity inadequacy</li> </ul>	<ul style="list-style-type: none"> <li>• Room should be done isolated.</li> </ul>
		<ul style="list-style-type: none"> <li>• Change the fuel.</li> </ul>
		<ul style="list-style-type: none"> <li>• House heat need to be checked</li> </ul>
<ul style="list-style-type: none"> <li>• <b>Grill swinging rods does not move</b></li> </ul>	<ul style="list-style-type: none"> <li>• Coal or hard object is stuck between the grid.</li> </ul>	<ul style="list-style-type: none"> <li>• Grid need to be checked and clean.</li> </ul>
<ul style="list-style-type: none"> <li>• <b>Some radiators have a heating problem.</b></li> </ul>	<ul style="list-style-type: none"> <li>• Unwarming radiators may have air.</li> </ul>	<ul style="list-style-type: none"> <li>• Check the air of the radiators</li> </ul>
	<ul style="list-style-type: none"> <li>• Pipe selection with incorrect diameter</li> </ul>	<ul style="list-style-type: none"> <li>• Pipe diameter calculation must be done correctly</li> </ul>
<ul style="list-style-type: none"> <li>• <b>Pump does not work.</b></li> </ul>	<ul style="list-style-type: none"> <li>• The thermostat may be faulty.</li> </ul>	<ul style="list-style-type: none"> <li>• Make sure the thermostat is working</li> </ul>

<ul style="list-style-type: none"> <li>• <b>Pump circulation is not working</b></li> </ul>	<ul style="list-style-type: none"> <li>• There is an air jam in the pump.</li> </ul>	<ul style="list-style-type: none"> <li>• The air in the pump will be automatically thrown away.</li> </ul>
<ul style="list-style-type: none"> <li>• <b>The air inside the pump can not be dispensed.</b></li> </ul>	<ul style="list-style-type: none"> <li>• There may be an air jam in the pump wheel.</li> </ul>	<ul style="list-style-type: none"> <li>• Check the lights on the pump. Information on lights is included in the userguide.</li> </ul>
<ul style="list-style-type: none"> <li>• <b>The stove overheats even though the air clap is minimized.</b></li> </ul>	<ul style="list-style-type: none"> <li>• In front of the air flap, a foreign substance may have arrived.</li> </ul>	<ul style="list-style-type: none"> <li>• Take out the ashpit from your stove and clean the front of the air clap.</li> </ul>
<ul style="list-style-type: none"> <li>• <b>Stoves and chimneys often are pitch</b></li> </ul>	<ul style="list-style-type: none"> <li>• Poor quality coal use</li> </ul>	<ul style="list-style-type: none"> <li>• Clean around the air clap by removing the rear sub-sheet of the stove.</li> </ul>
	<ul style="list-style-type: none"> <li>• Fuel usage not recommended by our company in the stove</li> </ul>	<ul style="list-style-type: none"> <li>• Change the fuel</li> </ul>
	<ul style="list-style-type: none"> <li>• Burning at low temperature or exceeding capacity</li> </ul>	<ul style="list-style-type: none"> <li>• Do not burn the stove at low temperatures. Make sure the heat of the furnace can meet your needs.</li> </ul>
	<ul style="list-style-type: none"> <li>• Inadequate combustion air</li> </ul>	<ul style="list-style-type: none"> <li>• Check the ventilation of the room where the stove is placed.</li> </ul>
	<ul style="list-style-type: none"> <li>• Inadequate chimney draft</li> </ul>	<ul style="list-style-type: none"> <li>• Increase the chimney draught.</li> </ul>
<ul style="list-style-type: none"> <li>• <b>Although the stove is at the desired temperature, the ambient is not warming up.</b></li> </ul>	<ul style="list-style-type: none"> <li>• Installation problem</li> <li>• There may be air in installation system.             <ul style="list-style-type: none"> <li>• Isolation failure</li> <li>• Selection of stove in insufficient heat power</li> </ul> </li> </ul>	<ul style="list-style-type: none"> <li>• Check the pipe insulation, building insulation and radiator quantity-dimensions.             <ul style="list-style-type: none"> <li>• Select the stove suitable for the ambient temperature need</li> </ul> </li> </ul>

## 12. SIGNIFICANT INSTRUCTIONS for EFFECTIVE USING

- Ensure that the ashtray and the combustion chamber are clean before firing the stove.
- Please clean the inside of the glazed models with the help of cleaner and outside with the clean cloth.
- The insulated environment is recommended to use the stove.
- This stove is for houses, offices and internal places. There will be loss of energy and efficiency in balcony, warehouse or etc.
- Fuel should not be put into the combustion chamber of the stoves other than the defined fuels.
- Use defined fuel to ensure long life and efficient combustion of the boiler (see Fuel specifications)
- Please press the shut-down button to close the stove when the stove is open (do not take off the energy cable to turn off the stove).
- The chimney installation must be done in accordance with the instructions.
- Annual maintenance will make longer the life of the stove.
- Stove, chimney maintenance and cleaning should be done at least 2 (two) times per year depending on the type of fuel used.
- Recommended heating power must be calculated for the thermal power of the used area.
- Installation pipe diameters must be suitable for installation requirements.

## 13. SUGGESTIONS and FEEDBACK

- Please read the installation schema and user guide carefully.
- Once a year, the stove should be checked by the authorized stove.
- Please do not start the stove when the stove door is open.
- In case of fire, please switch off the stove and plug off, ventilate the room, call the emergency fire department.
- **Please use suggested fuels.**
- **Please follow the user instructions.**

**İFYIL TERMO İKLİMLENDİRME SAN. Ve TİC. LTD. ŞTİ.**

### CONTACT INFO

**Phone:** +90 (362) 266 94 43

**Fax:** +90 (362) 266 94 43

**E-mail:** [info@ifyil.com.tr](mailto:info@ifyil.com.tr)

**Address:** Yeni Cami Mah. 3. Cad. Kavak OSB Kavak/ SAMSUN/TÜRKİYE

**THANK YOU FOR PREFERING İFYIL QUALITY...!**



#### Service Calls

For technical service calls, please visit [www.ifyil.com.tr](http://www.ifyil.com.tr)



**Any right cannot be claimed due to the changes or modifications or wrong use of spare parts. İFYIL original spare parts must be used for any permitted change of spare part.**



# REPUBLIC OF TURKEY

MINISTRY OF CUSTOMS AND TRADE

DIRECTORY OF CUSTOMERS  
PROTECTION AND MARKET  
SURVEILLANCE



## CERTIFICATE OF WARRANTY

Date of issue and number of document:

Validity of document:

The Ministry of Customs and Trade with General Directorate of Consumer Protection and Market Surveillance authorized use of this document; Law No. 6502 on Consumer Protection and In accordance with the Regulation on the application principles of the WARRANTY Certificate.

### MANUFACTURER COMPANY

Name: İFYİL TERMO  
İKLİMLENDİRME SAN.  
TİC. LTD. ŞTİ.

Address: Yeni Cami Mah. 3. Cad.  
Kavak OSB Kavak/  
SAMSUN/TÜRKİYE

Phone: +90 (362) 266 94 43

Fax: +90 (362) 266 94 43

E-Mail: info@ifyil.com.tr

Authorized

Signature & Stamp

İFYİL TERMO İKLİMLENDİRME  
SANAYİ VE TİCARET LTD. ŞTİ.  
Yeni Cami Mah. 3. Cad. No:11 Kavak OSB  
Tel-Fax: (0362) 266 94 43 Kavak/SAMSUN  
Kavak Mal. MÜDÜRLÜĞÜ : 470 043 0490  
Mersis No.: 0470 - 0630 - 4900 - 0014

### PRODUCT

Type: Solid Fuel Hydro Stove / Cooker

Trademark: İFYİL

Model:

Banderole & Serial Number:

Production Date:

Warranty Time: Two Years

Max Reperation Time: Twenty Working Days

### IMPORTER / DEALER

Name:

Address:

Phone:

Fax:

E-Mail:

Invoice date and number:

Delivery date and place:

Authorized Signature:

Authorized Stamp:

### CUSTOMER

Name Surname:

Address:

Phone:

Signature:

# WARRANTY CONDITIONS

- 1) The warranty period starts from the delivery date of the product and is **two (2)** years.
  - 2) The product is fully in warranty, except for the glass and cast parts.
  - 3) In case the product is found to be defective, Article 11 of the Law No. 6502 on Consumer Protection;
    - a- **Cancelling sales contract,**
    - b- **Asking for reduction from selling price of products,**
    - c- **Asking for free reparation,**
    - d- **Asking products to be changed with non defective one** use one of this rights.
  - 4) **In case of choosing product to be repered by consumer;** seller is obliged to repare total product without asking any reparation fee, changed parts or any costs concerning this reparation. Consumer can use this right either against manufacturer or against importer of products. Seller, manufacturer and importer are common responsible for quality of products.
  - 5) **In case of choosing products to be repered for free by consumer;**
    - If products are broken again in the warranty time is still,
    - If given repair time was passed,
    - If reparation is impossible and this situation is proved by service, seller, manufacturer or importer with a written report;
- Consumer has total right to ask be paid the price of products, reduction price of product for damage or if possible change of completely product against not damaged ones.** Seller has no right to refuse demand written here below and in negative case seller, manufacturer and importer are common responsible.
- 6) Reparation period can not exceed **20 working days**. In case of in warranty time this period starts from to giving information time to tecnical service or seller by customer. In case of in not valid warranty time this period starts from reception of the products to service. Importer or seller obliged to replace products with another one until reparation completed, if reparation period exceeds **10 working days**. Time for reparation will be added to total warranty time in case reparation has been done on validity of warranty term.
  - 7) Warranty does not covers any damages due to energy cut in case of not use external power supply.
  - 8) Warranty does not cover any damages due to high or low voltage.
  - 9) Warranty does not covers any damages due to burning chemical used fuels or damp fuels.
  - 10) Product will out of Warranty when installation/any change made by non authorised personnel or services.

- 11) Warranty does not covers any damages due to set up ifyil stoves in open air areas, wet places, humid places or any place which directly related to all these places.
- 12) Warranty does not cover any damages due to not maintenance of product which written in user's guide.
- 13) Warranty does not cover any damages due to using product against its purpose or against rules written in user's guide.
- 14) Warranty does not cover any damages due to **fire and natural disaster**.
- 15) Consumer has total right to inform courts, consumer arbitration committee of their country or place of live.
- 16) In case not issue of this warranty certificate consumer has right to apply to ministry of trade and customs of Turkish Republic.
- 17) This warranty rules and conditions are valid only in territory of **Turkish Republic** and in case of arbitration courts of Samsun city Turkish Republic are authorized.
- 18) Service and warranty terms are the responsibility of the importer Company.



"sımsıcak mekanlar için..."



**IFYIL TERMO İklimlendirme San. Ve Tic. Ltd. Şti.**

Kavak Organize Sanayi Bölgesi 3. Cad. No.11 Kavak / Samsun / Türkiye

Tel : +90 362 266 9443 Fax : +90 362 266 9443 Mail : info@ifyil.com.tr

[www.ifyil.com.tr](http://www.ifyil.com.tr)