

TROY

HYDRO PELLET STOVE

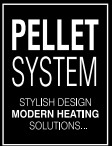

A⁺
DM186 / Class 4

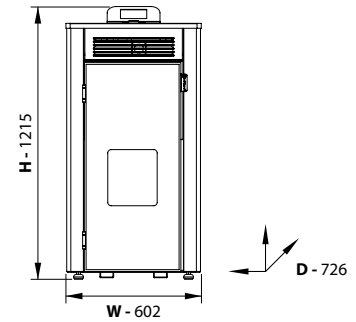

IMQ
primocontrol



EN 14785

BlmSchV 2



CONTO
TERMICO 2.0



- Modulated combustion
- Digital control panel
- Automatic ignition
- Fully automatic cleaning furnace
- Manual turbulator cleaning system
- Extractor Fan
- Chorono (Weekly Programing)
- Room thermostat connection
- BackFlame protection
- Fireplace view
- Heating system
- Hot water exchanger (optional)
- Wi-Fi - Wireless connection (optional)
- Pellet fueled



- Modulierte Verbrennung
- Digitales Bedienfeld
- Automatische Zündung
- Vollautomatischer Reinigungssofen
- Manuelles Turbulatorreinigungssystem
- Abzugsventilator
- Wöchentliche Programmierung Chorono
- Raumthermostatanschluss
- Zurück Flammenschutz
- Blick auf den Kamin
- Heizungssystem
- Warmwassertauscher (optional)
- Wi-Fi - kabellose Verbindung (optional)
- Pellets befeuert



- Combustión modulada
- Panel de control digital y menú turco.
- Encendido automático
- Horno de limpieza totalmente automático.
- Sistema de limpieza manual del turbulador.
- Ventilador extractor
- Programación semanal
- Conexión de termostato de habitación.
- Protección de contraluz
- Vista de la chimenea
- Sistema de calefacción
- Intercambiador de agua caliente (opcional)
- Wi-Fi - Conexión inalámbrica (opcional)
- Pellet alimentado



- Combustion modulée
- Panneau de commande numérique et menu turc
- Allumage automatique
- Four de nettoyage entièrement automatique
- Système de nettoyage manuel du turbulateur
- Ventilateur d'extraction
- Programmation hebdomadaire
- Connexion du thermostat d'ambiance
- Protection contre le contre-jour
- vue de la cheminée
- Système de chauffage
- échangeur d'eau chaude (en option)
- Wi-Fi - connexion sans fil (facultatif)
- Granulés alimentés



- модулированное сгорание
- Цифровая панель управления
- автоматическое зажигание
- Полностью автоматическая очистка печи
- Ручная система очистки турбулизатора
- Вытяжка
- Ежедневное программирование
- Подключение комнатного термостата
- Подсветка защиты
- Вид на камин
- Система обогрева
- Теплообменник горячей воды (опция)
- Wi-Fi - беспроводное соединение (опция)
- Пеллет заправляется



- Combustione modulata
- Pannello di controllo digitale
- Accensione automatica
- Forno per la pulizia completamente automatico
- Sistema di pulizia manuale del turbolatore
- Extractor fan
- Programmazione settimanale Chrono
- Connessione del termostato ambiente
- Protezione contro luce
- Vista del camino
- Sistema di riscaldamento
- Scambiatore di acqua calda (opzionale)
- Wi-Fi - Connessione wireless (opzionale)
- Combustibile a pellet

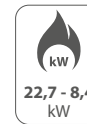

22,7 - 8,4
kW



19,4
kW

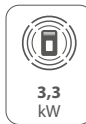

3,3
kW

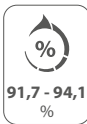

91,7 - 94,1
%



5,25 - 1,89
kg / h



32 - 53
kg - lt



222
kg



Ø 100
mm



Claret Red



Grey



Dark Cream



IFYIL

www.ifyil.com.tr

FREEDOM

HYDRO PELLET STOVE

PELLET SYSTEM
STYLISH DESIGN
MODERN HEATING
SOLUTIONS...



A⁺
DM186 / Class 5

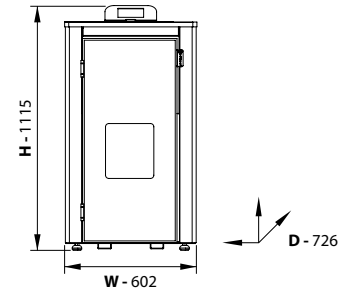

Итем **CE EN 14785** **BlmSchV 2** **DM186** **CONTO TERMICO 2.0**



- Modulated combustion
- Digital control panel
- Automatic ignition
- Fully automatic cleaning furnace
- Manual turbulator cleaning system
- Extractor Fan
- Chorono (Weekly Programing)
- Room thermostat connection
- BackFlame protection
- Fireplace view
- Heating system
- Hot water exchanger (optional)
- Wi-Fi - Wireless connection (optional)
- Pellet fueled



- Modulierende Verbrennung
- Digitales Bedienfeld
- Automatische Zündung
- Vollautomatischer Reinigungssofen
- Manuelles Turbulatorreinigungssystem
- Abzugsventilator
- Wöchentliche Programmierung Chorono
- Raumthermostatanschluss
- Zurück Flammschutz
- Blick auf den Kamin
- Heizungssystem
- Warmwassertauscher (optional)
- Wi-Fi - kabellose Verbindung (optional)
- Pellets befeuert



- Combustión modulada
- Panel de control digital y menú turco.
- Encendido automático
- Horno de limpieza totalmente automático.
- Sistema de limpieza manual del turbulador.
- Ventilador extractor
- Programación semanal
- Conexión de termostato de habitación.
- Protección de contraluz
- vista de la chimenea
- Sistema de calefacción
- Intercambiador de agua caliente (opcional)
- Wi-Fi - Conexión inalámbrica (opcional)
- Pellet alimentado



- Combustion modulée
- Panneau de commande numérique et menu turc
- Allumage automatique
- Four de nettoyage entièrement automatique
- Système de nettoyage manuel du turbulateur
- Ventilateur d'extraction
- Programmation hebdomadaire
- Connexion du thermostat d'ambiance
- Protection contre le contre-jour
- Vue de la cheminée
- Système de chauffage
- échangeur d'eau chaude (en option)
- Wi-Fi - connexion sans fil (facultatif)
- Granulés alimentés



- модулированное сгорание
- Цифровая панель управления
- автоматическое зажигание
- Полностью автоматическая очистка печи
- Ручная система очистки турбулизатора
- Вытяжка
- Ежедневное программирование
- Подключение комнатного термостата
- Подсветка защиты
- Вид на камин
- Система обогрева
- Теплообменник горячей воды (опция)
- Wi-Fi - беспроводное соединение (опция)
- Пеллет заправляется



- Combustione modulata
- Pannello di controllo digitale
- Accensione automatica
- Forno per la pulizia completamente automatico
- Sistema di pulizia manuale del turbolatore
- Extractor fan
- Programmazione settimanale Chrono
- Connessione del termostato ambiente
- Protezione controluce
- Vista del camino
- Sistema di riscaldamento
- Scambiatore di acqua calda (opzionale)
- Wi-Fi - Connessione wireless (opzionale)
- Combustibile a pellet

 16 - 4,8 kW	 15 kW	 1 kW	 95 - 96 %
 3,5 - 1,05 kg / h	 25 - 42 kg - lt	 216 kg	 Ø 100 mm

Claret Red

Grey

Dark Cream



IFYIL®

www.ifyil.com.tr

BOSPHORUS

HYDRO PELLET CUISINE STOVE

PELLET SYSTEM
 STYLISH DESIGN
 MODERN HEATING
 SOLUTIONS...

A++

DM186 / Class 5

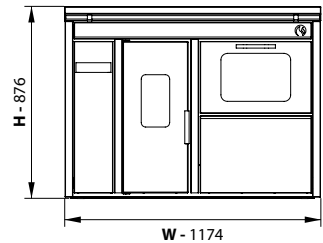

D - 704

Item **CE EN 12815** **BlmSchV 2** **DM186 2017 5** **CONTO TERMICO 2.0**



- Modulated combustion
- Digital control panel
- Automatic ignition
- Fully automatic cleaning furnace
- Manual turbulator cleaning system
- Extractor Fan
- Chorono (Weekly Programming)
- Room thermostat connection
- Back flame protection
- Ceramic glass cooking place
- Large useful chromium furnace (3 steps)
- Soft close oven door
- Fireplace view
- Heating system
- Hot water exchanger (optional)
- Wi-Fi - Wireless connection (optional)
- Pellet fueled



- Modulierende Verbrennung
- Digitales Bedienfeld
- Automatische Zündung
- Vollautomatischer Reinigungssofen
- Manuelles Turbulatorreinigungssystem
- Abzugsventilator
- Wöchentliche Programmierung Chorono
- Raumthermostatanschluss
- Rückwärts Verbrennungsschutz
- Kochstelle aus Keramikglas
- Großer nützlicher Chromofen (3 Stufen)
- Backofentür schließen
- Blick auf den Kamin
- Heizungssystem
- Warmwassertauscher (optional)
- Wi-Fi - kabellose Verbindung (optional)
- Pellet Brennstoff



- Combustión modulada
- Panel de control digital y menú turco.
- Encendido automático
- Horno de limpieza totalmente automático.
- Sistema de limpieza manual del turbulador.
- Ventilador extractor
- Programación semanal
- Conexión de termostato de habitación.
- Protección de contraluz
- Cocina vitrocerámica.
- Gran horno de cromo útil (3 pasos)
- Cierre suave de la puerta del horno
- vista de la chimenea
- Sistema de calefacción
- Intercambiador de agua caliente (opcional)
- Wi-Fi - Conexión inalámbrica (opcional)
- Pellet alimentado



- Combustion modulée
- Panneau de commande numérique et menu turc
- Allumage automatique
- Four de nettoyage entièrement automatique
- Système de nettoyage manuel du turbulateur
- Ventilateur d'extraction
- Programmation hebdomadaire
- Connexion du thermostat d'ambiance
- Protection contre le contre-jour
- lieu de cuisson en verre céramique
- Grand four à chrome utile (3 étapes)
- Porte du four à fermeture douce
- vue de la cheminée
- système de chauffage
- échangeur d'eau chaude (en option)
- Wi-Fi - connexion sans fil (facultatif)
- Granulés alimentés



- модулированное сгорание
- Цифровая панель управления
- автоматическое зажигание
- Полностью автоматическая очистка печи
- Ручная система очистки турбулизатора
- Вытяжка
- Еженедельное программирование
- Подключение комнатного термостата
- Подсветка защиты
- Место для приготовления керамического стекла
- Большая полезная хромовая печь (3 ступени)
- Мягкая дверца духовки
- Вид на камин
- Система обогрева
- Теплообменник горячей воды (опция)
- Wi-Fi - беспроводное соединение (опция)
- Пеллет управляется



- Combustione modulata
- Pannello di controllo digitale
- Accensione automatica
- Forno per la pulizia completamente automatico
- Sistema di pulizia manuale del turbolatore
- Extractor fan
- Programmazione settimanale Chrono
- Connessione del termostato ambiente
- Protezione controllo
- Posto di cottura in vetro ceramico
- Forno di cromo utile di grandi dimensioni (3 gradini)
- Porta del forno silenziosa
- Vista del camino
- Sistema di riscaldamento
- Scambiatore di acqua calda (opzionale)
- Wi-Fi - Connessione wireless (opzionale)
- Combustibile a pellet

 22 - 6,6 kW	 14 kW	 8 kW	 93 - 96 %
 4,9 - 1,47 kg / h	 26 - 43 kg - lt	 265 kg	 Ø 100 mm

Claret Red

Grey

Dark Cream

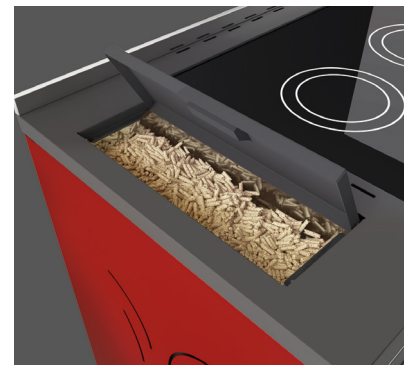

IFYIL

www.ifyil.com.tr

CRYSTAL

AIR PELLET STOVE CANALIZABLE

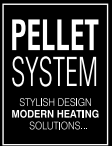

A⁺
DM186 / Class 5

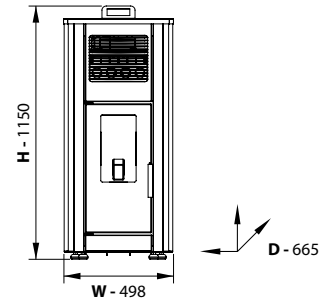

Итем **CE EN 14785** **B1mSchV 2** **DM186 5** **CONTO TERMICO 2.0**



- Modulated combustion
- Digital control panel
- Automatic ignition
- Manually clean burning pot
- Extractor Fan
- Weekly programming Chrono
- Room thermostat connection
- BackFlame protection
- Hot air blowing to ambiente Room
- Canalizable
- Fireplace view
- Wi-Fi - Wireless connection (optional)
- Pellet fueled



- Modulierende Verbrennung
- Digitales Bedienfeld
- Automatische Zündung
- Brennerkopf manuell reinigen
- Abzugsventilator
- Wöchentliche Programmierung von Chrono
- Raumthermostatanschluss
- Rückwärts Verbrennungsschutz
- Heissluft bläst in den Ambient Room
- Kanalisierbar
- Blick auf den Kamin
- Wi-Fi - kabellose Verbindung (optional)
- Pellet Brennstoff



- Combustión modulada
- Panel de control digital
- Encendido automático
- Limpiar manualmente la olla de combustión
- Ventilador extractor
- Programación semanal de chrono.
- Conexión de termostato de habitación.
- Protección BackFlame
- Aire caliente soplando a la sala ambiente.
- Canalizable
- Vista de la chimenea
- Wi-Fi - Conexión inalámbrica (opcional)
- Pellet alimentado



- Combustion modulée
- Panneau de commande numérique
- Allumage automatique
- Nettoyer manuellement le pot de combustion
- Ventilateur d'extraction
- Programmation hebdomadaire Chrono
- Connexion du thermostat d'ambiance
- Protection BackFlame
- Air chaud soufflant dans la pièce
- Canalizable
- Vue de la cheminée
- Wi-Fi - connexion sans fil (facultatif)
- Granulés alimentés



- модулированное сгорание
- Цифровая панель управления
- автоматическое зажигание
- Ручная чистка горелки
- Вытяжка
- Еженедельное программирование Chrono
- Подключение комнатного термостата
- Защита заднего пламени
- Горячий воздух, дующий в помещение
- Canalizable
- Вид на камин
- Wi-Fi - беспроводное соединение (опция)
- Пеллет заправляется



- Combustione modulata
- Pannello di controllo digitale
- Accensione automatica
- Pulire a mano pentola bruciata
- Extractor fan
- Programmazione settimanale Chrono
- Connessione del termostato ambiente
- Protezione BackFlame
- Aria calda che soffia verso la camera ambiente
- Canalizzabile
- Vista del camino
- Wi-Fi - Connessione wireless (opzionale)
- Combustibile a pellet

 10 - 3 kW	 10 kW	 88 - 89 %	 2,5 - 0,75 kg / h
 287 (*) m³	 23 - 38 kg - lt	 137 kg	 Ø 80 mm

(*) The maximum heating volume may depend on the ambient room conditions

- Claret Red
- Grey
- Dark Cream



IFYIL

www.ifyil.com.tr

THERMAL

AIR PELLET STOVE

PELLET SYSTEM
STYLISH DESIGN
MODERN HEATING SOLUTIONS...



A⁺
DM186 / Class 5

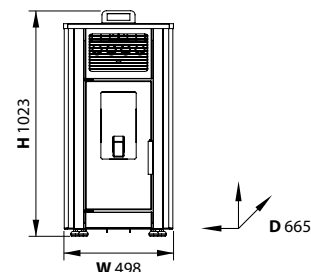

CE EN 14785 BlmSchV 2 **DM186** **CONTO TERMICO 2.0**



- Modulated combustion
- Digital control panel
- Automatic ignition
- Manually clean burning pot
- Extractor Fan
- Weekly programming Choroно
- Room thermostat connection
- BackFlame protection
- Hot air blowing to ambiente Room
- Fireplace view
- Wi-Fi - Wireless connection (optional)
- Pellet fueled



- Modulierende Verbrennung
- Digitales Bedienfeld
- Automatische Zündung
- Brenntopf manuell reinigen
- Abzugsventilator
- Wöchentliche Programmierung von Choroно
- Raumthermostatanschluss
- Rückwärts Verbrennungsschutz
- Heissluft bläst in den Ambient Room
- Blick auf den Kamin
- Wi-Fi - kabellose Verbindung (optional)
- Pellet Brennstoff



- Combustión modulada
- Panel de control digital
- Encendido automático
- Limpiar manualmente la olla de combustión
- Ventilador extractor
- Programación semanal de choroно.
- Conexión de termostato de habitación.
- Protección BackFlame
- Aire caliente soplando a la sala ambiente.
- vista de la chimenea
- Wi-Fi - Conexión inalámbrica (opcional)
- Pellet alimentado



- Combustion modulée
- Panneau de commande numérique
- Allumage automatique
- Nettoyer manuellement le pot de combustion
- Ventilateur d'extraction
- Programmation hebdomadaire Choroно
- Connexion du thermostat d'ambiance
- Protection BackFlame
- Air chaud soufflant dans la pièce
- Vue de la cheminée
- Wi-Fi - connexion sans fil (facultatif)
- Granulés alimentés



- модулированное сгорание
- Цифровая панель управления
- автоматическое зажигание
- Ручная чистка горелки
- Вытяжка
- Ежедневное программирование Choroно
- Подключение комнатного термостата
- Защита заднего пламени
- Горячий воздух, дующий в помещение
- Вид на камин
- Wi-Fi - беспроводное соединение (опция)
- Пеллет заправляется



- Combustione modulata
- Pannello di controllo digitale
- Accensione automatica
- Pulire a mano pentola bruciata
- Extractor fan
- Programmazione settimanale Choroно
- Connessione del termostato ambiente
- Protezione BackFlame
- Aria calda che soffia verso la camera ambiente
- Vista del camino
- Wi-Fi - Connessione wireless (opzionale)
- Combustibile a pellet

 8 - 2,4 kW	 8 kW	 88 - 89 %	 2,00 - 0,60 kg / h
 230 (*) m ³	 17 - 28 kg - lt	 127 kg	 Ø 80 mm

(*) The maximum heating volume may depend on the ambient room conditions

- Claret Red
- Grey
- Dark Cream



IFYIL

www.ifyil.com.tr

PERGAMON

AIR PELLET STOVE

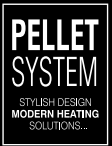

A⁺
DM186 / Class 5

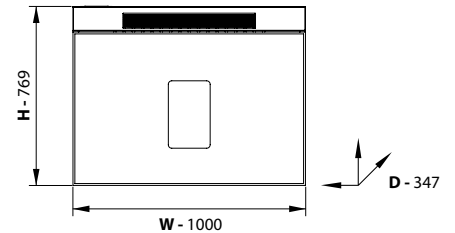

CE EN 14785 BlmSchV 2 **DM186 2012 5** **CONTO TERMICO 2.0**



- Modulated combustion
- Digital control panel
- Automatic ignition
- Manually clean burning pot
- Extractor Fan
- Weekly programming Chorono
- Room thermostat connection
- BackFlame protection
- Hot air blowing to ambiente Room
- Fireplace view
- Wi-Fi - Wireless connection (optional)
- Pellet fueled



- Modulierende Verbrennung
- Digitales Bedienfeld
- Automatische Zündung
- Brenntopf manuell reinigen
- Abzugsventilator
- Wöchentliche Programmierung von Chorono
- Raumthermostatanschluss
- Rückwärts Verbrennungsschutz
- Heissluft bläst in den Ambient Room
- Blick auf den Kamin
- Wi-Fi - kabellose Verbindung (optional)
- Pellet Brennstoff



- Combustión modulada
- Panel de control digital
- Encendido automático
- Limpiar manualmente la olla de combustión
- Ventilador extractor
- Programación semanal de chorono.
- Conexión de termostato de habitación.
- Protección BackFlame
- Aire caliente soplando a la sala ambiente.
- vista de la chimenea
- Wi-Fi - Conexión inalámbrica (opcional)
- Pellet alimentado



- Combustion modulée
- Panneau de commande numérique
- Allumage automatique
- Nettoyer manuellement le pot de combustion
- Ventilateur d'extraction
- Programmation hebdomadaire Chorono
- Connexion du thermostat d'ambiance
- Protection BackFlame
- Air chaud soufflant dans la pièce
- Vue de la cheminée
- Wi-Fi - connexion sans fil (facultatif)
- Granulés alimentés



- модулированное сгорание
- Цифровая панель управления
- автоматическое зажигание
- Ручная чистка горелки
- Вытяжка
- Ежедневное программирование Chorono
- Подключение комнатного термостата
- Защита заднего пламени
- Горячий воздух, дующий в помещение
- Вид на камин
- Wi-Fi - беспроводное соединение (опция)
- Пеллет заправляется



- Combustione modulata
- Pannello di controllo digitale
- Accensione automatica
- Pulire a mano pentola bruciata
- Extractor fan
- Programmazione settimanale Chorono
- Connessione del termostato ambiente
- Protezione BackFlame
- Aria calda che soffia verso la camera ambiente
- Vista del camino
- Wi-Fi - Connessione wireless (opzionale)
- Combustibile a pellet

5 - 1,5 kW	5 kW	88,2 - 89,3 %	1,2 - 0,36 kg / h
143 (*) m³	10 - 16,7 kg - lt	152 kg	Ø 80 mm

(*) The maximum heating volume may depend on the ambient room conditions



Black



www.ifyil.com.tr

STAR

HYDRO COOKING WOOD STOVE

FOUR
POWERFUL
ADVANTAGES
CENTRAL HEATING
HOT WATER
STOVE & FIREPLACE



Eco
Friendly

A⁺
DM186 / Class 3

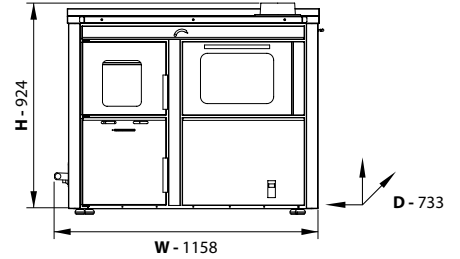

Итем **CE EN 12815 BlmSchV 2** **DM186** **CONTO TERMICO 2.0**



- Tilt grill cleaning system
- Semi-auto 1st air control
- Manual 2nd combustion air control
- Safety valve safety device
- Cooking on top table
- Large, handy chrome oven (3 steps)
- Fireplace view
- Front and top loading
- Heater system
- Hot water exchanger (optional)
- Wood, briquettes and coal burning
- Soft close oven door



- Kippender Grill Reinigungssystem
- Halb-Auto 1st Luft Control
- Manuelle 2. Verbrennungsluftsteuerung
- Sicherheitsventil-Sicherheitsvorrichtung
- Kochen am oberen Tisch
- Großer, breiter Chromofen (3 Stufen)
- Blick auf den Kamin
- Front- und Toplader
- Heizsystem
- Warmwassertauscher (optional)
- Holz, Briketts und Kohleverbrennung
- Backofentür schließen

- Système de nettoyage du grill incliné
- 1er contrôle d'air semi-automatique
- Commande manuelle du 2e air de combustion
- Dispositif de sécurité de soupape de sécurité
- Cuisson sur la table
- Grand four chromé pratique (3 marches)
- Vue de la cheminée
- Chargement frontal et supérieur
- Système de chauffage
- échangeur d'eau chaude (en option)
- Bois, briquettes et charbon
- Porte du four à fermeture douce

- Sistema di pulizia della griglia di inclinazione
- 1° controllo dell'aria semi-automatico
- Manuale 2° controllo dell'aria di combustione
- Dispositivo di sicurezza della valvola di sicurezza
- Cottura sul tavolo in alto
- Ampio e maneggevole forno al cromo (3 gradini)
- Vista del camino
- Caricamento frontale e superiore
- Sistema di riscaldamento
- Scambiatore di acqua calda (opzionale)
- Legno, mattonelle e carbone
- Porta del forno silenziosa

- Sistema de limpieza de la parrilla de inclinación
- Semi-auto 1er control de aire
- Control manual de aire de 2ª combustión
- Dispositivo de seguridad de válvula de seguridad
- Cocinar en mesa superior
- Horno de cromo grande y manejable (3 pasos)
- Vista de la chimenea
- Carga frontal y superior
- Sistema de calefacción
- Intercambiador de agua caliente (opcional)
- Madera, briquetas y quema de carbón
- Cierre suave de la puerta del horno

- Система очистки наклона гриля
- 1-й полуавтоматический контроль воздуха
- Ручной 2-й контроль воздуха для горения
- предохранительное устройство
- Готовить на верхнем столе
- Большая, удобная хромированная духовка (3 ступени)
- Вид на камин
- Передняя и верхняя загрузка
- Система обогрева
- Теплообменник горячей воды (опция)
- сжигание древесины, брикетов и угля
- Мягкая дверца духовки

Wood 23 kW | **Briquette 24 kW** | **Coal 34,5 kW**

H₂O **Wood 18 kW** | **Briquette 18 kW** | **Coal 27 kW**

Wood 5 kW | **Briquette 6 kW** | **Coal 7,5 kW**

84,93 %

296 kg

Ø 150 mm

Claret Red

Grey

Dark Cream



IFYIL

www.ifyil.com.tr

ROASTER

HYDRO COOKING WOOD STOVE

FOUR
POWERFUL
ADVANTAGES
CENTRAL HEATING
HOT WATER
STOVE & FIREPLACE



A⁺
DM186 / Class 4

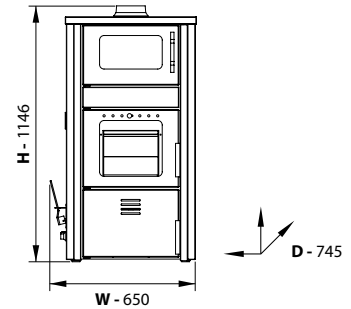

Итем **CE EN 13240 BImSchV 2** **DM186**



- Tilt grill cleaning system
- Semi-auto 1st air control
- Manual 2nd combustion air control
- Safety valve safety device
- Cooking on top table
- Large, handy chrome oven (3 steps)
- Fireplace view
- Front and top loading
- Heater system
- Hot water exchanger (optional)
- Wood, briquettes and coal burning
- Soft close oven door



- Kippender Grill Reinigungssystem
- Halb-Auto 1st Luft Control
- Manuelle 2. Verbrennungsluftsteuerung
- Sicherheitsventil-Sicherheitsvorrichtung
- Kochen am oberen Tisch
- Großer, breiter Chromofen (3 Stufen)
- Blick auf den Kamin
- Front- und Toplader
- Heizsystem
- Warmwassertaucher (optional)
- Holz, Briketts und Kohleverbrennung
- Backofentür schließen



- Système de nettoyage du grill incliné
- 1er contrôle d'air semi-automatique
- Commande manuelle du 2e air de combustion
- Dispositif de sécurité de soupape de sécurité
- Cuisson sur la table
- Grand four chromé pratique (3 marches)
- Vue de la cheminée
- Chargement frontal et supérieur
- Système de chauffage
- échangeur d'eau chaude (en option)
- Bois, briquettes et charbon
- Porte du four à fermeture douce



- Sistema di pulizia della griglia di inclinazione
- 1° controllo dell'aria semi-automatico
- Manuale 2° controllo dell'aria di combustione
- Dispositivo di sicurezza della valvola di sicurezza
- Cottura sul tavolo in alto
- Ampio e maneggevole forno al cromo (3 gradini)
- Vista del camino
- Caricamento frontale e superiore
- Sistema di riscaldamento
- Scambiatore di acqua calda (opzionale)
- Legno, mattonelle e carbone
- Porta del forno silenziosa



- Sistema de limpieza de la parrilla de inclinación
- Semi-auto 1er control de aire
- Control manual de aire de 2ª combustión
- Dispositivo de seguridad de válvula de seguridad
- Cocinar en mesa superior
- Horno de cromo grande y manejable (3 pasos)
- Vista de la chimenea
- Carga frontal y superior
- Sistema de calefacción
- Intercambiador de agua caliente (opcional)
- Madera, briquetas y quema de carbón
- Cierre suave de la puerta del horno



- Система очистки наклона гриля
- 1-й полуавтоматический контроль воздуха
- Ручной 2-й контроль воздуха для горения
- предохранительное устройство
- Готовить на верхнем столе
- Большая, удобная хромированная духовка (3 ступени)
- Вид на камин
- Передняя и верхняя загрузка
- Система обогрева
- Теплообменник горячей воды (опция)
- сжигание древесины, брикетов и угля
- Мягкая дверца духовки

	Wood 20 kW	Briquette 21 kW	Coal 32 kW
--	---------------	--------------------	---------------

	Wood 16 kW	Briquette 17 kW	Coal 26 kW
--	---------------	--------------------	---------------

	Wood 4 kW	Briquette 4 kW	Coal 6 kW
--	--------------	-------------------	--------------

	80 %
--	------

	229 kg
--	--------

	Ø 130 mm
--	----------



IFYIL

www.ifyil.com.tr

SUPERNOVA

HYDRO WOOD STOVE

FOUR
POWERFUL
ADVANTAGES
CENTRAL HEATING
HOT WATER
STOVE & FIREPLACE



Eco
Friendly

A+

DM186 / Class 4

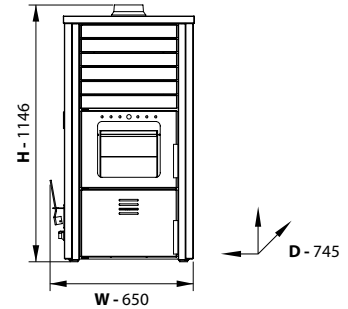

Итем **EN 13240** **BlmSchV 2** **DM186**
2017 **4**



- Tilt grill cleaning system
- Semi-auto 1st air control
- Manual 2nd combustion air control
- Safety valve safety device
- Cooking on top table
- Fireplace view
- Front and top loading
- Heater system
- Hot water exchanger (optional)
- Wood, briquettes and coal burning



- Kippender Grill Reinigungssystem
- Halb-Auto 1st Luft Control
- Manuelle 2. Verbrennungsluftsteuerung
- Sicherheitsventil-Sicherheitsvorrichtung
- Kochen am oberen Tisch
- Blick auf den Kamin
- Front- und Toplader
- Heizsystem
- Warmwassertauscher (optional)
- Holz, Briketts und Kohleverbrennung



- Système de nettoyage du grill incliné
- 1er contrôle d'air semi-automatique
- Commande manuelle du 2e air de combustion
- Dispositif de sécurité de soupape de sécurité
- Cuisson sur la table
- Vue de la cheminée
- Chargement frontal et supérieur
- Système de chauffage
- échangeur d'eau chaude (en option)
- Bois, briquettes et charbon



- Sistema di pulizia della griglia di inclinazione
- 1° controllo dell'aria semi-automatico
- Manuale 2° controllo dell'aria di combustione
- Dispositivo di sicurezza della valvola di sicurezza
- Cottura sul tavolo in alto
- Vista del camino
- Caricamento frontale e superiore
- Sistema di riscaldamento
- Scambiatore di acqua calda (opzionale)
- Legno, mattonelle e carbone



- Sistema de limpieza de la parrilla de inclinación
- Semi-auto 1er control de aire
- Control de aire de combustión secundaria manual
- Dispositivo de seguridad de válvula de seguridad
- Cocinar en mesa superior
- Vista de la chimenea
- Carga frontal y superior
- Sistema de calefacción
- Intercambiador de agua caliente (opcional)
- Madera, briquetas y quema de carbón



- Система очистки наклона гриля
- 1-й полуавтоматический контроль воздуха
- Ручной 2-й контроль воздуха для горения
- предохранительное устройство
- Готовить на верхнем столе
- Вид на камин
- Передняя и верхняя загрузка
- Система обогрева
- Теплообменник горячей воды (опция)
- сжигание древесины, брикетов и угля

	Wood 29 kW	Briquette 30 kW	Coal 38 kW
--	---------------	--------------------	---------------

	Wood 25 kW	Briquette 26 kW	Coal 34 kW
--	---------------	--------------------	---------------

	Wood 4 kW	Briquette 4 kW	Coal 4 kW
--	--------------	-------------------	--------------

	80 %
--	------

	211 kg
--	--------

	Ø 130 mm
--	----------



IFYIL

www.ifyil.com.tr

HAMMAM

HYDRO WOOD STOVE

FOUR
POWERFUL
ADVANTAGES
CENTRAL HEATING
HOT WATER
STOVE & FIREPLACE



A⁺
DM186 / Class 4

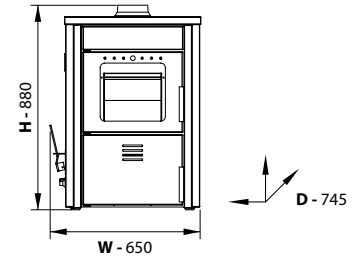

Итем **CE EN 13240 BImSchV 2** **DM186** **4**



- Tilt grill cleaning system
- Semi-auto 1st air control
- Manual 2nd combustion air control
- Safety valve safety device
- Cooking on top table
- Fireplace view
- Front and top loading
- Heater system
- Hot water exchanger (optional)
- Wood, briquettes and coal burning



- Sistema de limpieza de la parrilla de inclinación
- Semi-auto 1er control de aire
- Control de aire de combustión secundaria manual
- Dispositivo de seguridad de válvula de seguridad
- Cocinar en mesa superior
- vista de la chimenea
- Carga frontal y superior
- Sistema de calefacción
- Intercambiador de agua caliente (opcional)
- Madera, briquetas y quema de carbón



- Kippender Grill Reinigungssystem
- Halb-Auto 1st Luft Control
- Manuelle 2. Verbrennungsluftsteuerung
- Sicherheitsventil-Sicherheitsvorrichtung
- Kochen am oberen Tisch
- Blick auf den Kamin
- Front- und Toplader
- Heizsystem
- Warmwassertaucher (optional)
- Holz, Briketts und Kohleverbrennung



- Système de nettoyage du grill incliné
- 1er contrôle d'air semi-automatique
- Commande manuelle du 2e air de combustion
- Dispositif de sécurité de soupape de sécurité
- Cuisson sur la table
- Vue de la cheminée
- Chargement frontal et supérieur
- Système de chauffage
- échangeur d'eau chaude (en option)
- Bois, briquettes et charbon



- Sistema di pulizia della griglia di inclinazione
- 1° controllo dell'aria semi-automatico
- Manuale 2° controllo dell'aria di combustione
- Dispositivo di sicurezza della valvola di sicurezza
- Cottura sul tavolo in alto
- Vista del camino
- Caricamento frontale e superiore
- Sistema di riscaldamento
- Scambiatore di acqua calda (opzionale)
- Legno, mattonelle e carbone

	Wood 20 kW	Briquette 21 kW	Coal 32 kW
--	----------------------	---------------------------	----------------------

	Wood 16 kW	Briquette 17 kW	Coal 26 kW
--	----------------------	---------------------------	----------------------

	Wood 4 kW	Briquette 4 kW	Coal 6 kW
--	---------------------	--------------------------	---------------------

80 %

180 kg

Ø 130 mm

Claret Red

Grey

Dark Cream



IFYIL

www.ifyil.com.tr

SAUNA

HYDRO WOOD STOVE

FOUR
POWERFUL
ADVANTAGES
CENTRAL HEATING
HOT WATER
STOVE & FIREPLACE



A⁺
DM186 / Class 4

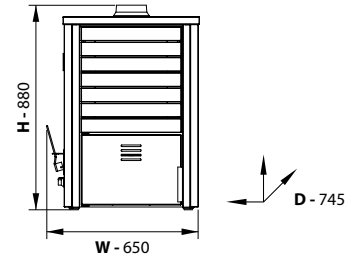

Итем **CE EN 13240 BlmSchV 2** **DM186** **2017** **4**



- Tilt grill cleaning system
- Semi-auto 1st air control
- Manual 2nd combustion air control
- Safety valve safety device
- Cooking on top table
- Front and top loading
- Heater system
- Hot water exchanger (optional)
- Wood, briquettes and coal burning



- Kippender Grill Reinigungssystem
- Halb-Auto 1st Luft Control
- Manuelle 2. Verbrennungsluftsteuerung
- Sicherheitsventil-Sicherheitsvorrichtung
- Kochen am oberen Tisch
- Front- und Toplader
- Heizsystem
- Warmwassertaucher (optional)
- Holz, Briketts und Kohleverbrennung



- Système de nettoyage du grill incliné
- 1er contrôle d'air semi-automatique
- Commande manuelle du 2e air de combustion
- Dispositif de sécurité de soupape de sécurité
- Cuisson sur la table
- Chargement frontal et supérieur
- Système de chauffage
- échangeur d'eau chaude (en option)
- Bois, briquettes et charbon



- Sistema di pulizia della griglia di inclinazione
- 1° controllo dell'aria semi-automatico
- Manuale 2° controllo dell'aria di combustione
- Dispositivo di sicurezza della valvola di sicurezza
- Cottura sul tavolo in alto
- Caricamento frontale e superiore
- Sistema di riscaldamento
- Scambiatore di acqua calda (opzionale)
- Legno, mattonelle e carbone



- Sistema de limpieza de la parrilla de inclinación
- Semi-auto 1er control de aire
- Control de aire de combustión secundaria manual
- Dispositivo de seguridad de válvula de seguridad
- Cocinar en mesa superior
- Carga frontal y superior
- Sistema de calefacción
- Intercambiador de agua caliente (opcional)
- Madera, briquetas y quema de carbón



- Система очистки наклона гриля
- 1-й полуавтоматический контроль воздуха
- Ручной 2-й контроль воздуха для горения
- предохранительное устройство
- Готовить на верхнем столе
- Передняя и верхняя загрузка
- Система обогрева
- Теплообменник горячей воды (опция)
- сжигание древесины, брикетов и угля

	Wood 20 kW	Briquette 21 kW	Coal 32 kW
--	----------------------	---------------------------	----------------------

	Wood 16 kW	Briquette 17 kW	Coal 26 kW
--	----------------------	---------------------------	----------------------

	Wood 4 kW	Briquette 4 kW	Coal 6 kW
--	---------------------	--------------------------	---------------------

80 %

182 kg

Ø 130 mm



Claret Red



Grey



Dark Cream



IFYIL

www.ifyil.com.tr

GT 15

PELLET BOILER

PELLET SYSTEM
STYLISH DESIGN
MODERN HEATING
SOLUTIONS...



A⁺

EN 303-5 / Class 5
DM186 / Class 4

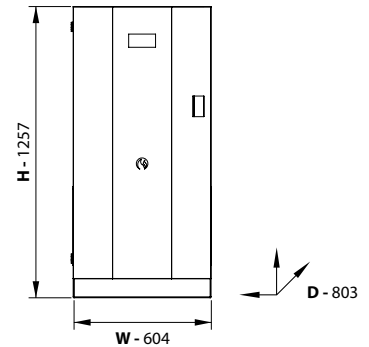

EN 303-5



BAFA
Bundesamt für Wirtschaft
und Ausfuhrkontrolle

BImSchV 2



CONTO TERMICO 2.0



- Modulated combustion
- Digital control panel
- Automatic ignition
- Fully automatic cleaning furnace
- Manual turbulator cleaning system
- Auto - turbo clean system (opt)
- Extractor Fan
- Chorono (Weekly Programing)
- Room thermostat connection
- BackFlame protection
- Heating system
- Hot water exchanger (optional)
- Wi-Fi - Wireless connection (optional)
- Pellet fueled



- Modulierende Verbrennung
- Digitales Bedienfeld
- Automatische Zündung
- Vollautomatischer Reinigungssofen
- Manuelles Turbulatorreinigungssystem
- Automatisches Turbulatorreinigungssystem (opt.)
- Abzugsventilator
- Wöchentliche Programmierung Chorono
- Raumthermostatanschluss
- Zurück Flammenschutz
- Heizungssystem
- Warmwassertauscher (optional)
- Wi-Fi - kabellose Verbindung (optional)
- Pellets befeuert



- Combustión modulada
- Panel de control digital y menú turco.
- Encendido automático
- Horno de limpieza totalmente automático.
- Sistema de limpieza manual del turbulador.
- Sistema automático de limpieza del turbulador (opc)
- Ventilador extractor
- Programación semanal
- Conexión de termostato de habitación.
- Protección de contraluz
- Sistema de calefacción
- Intercambiador de agua caliente (opcional)
- Wi-Fi - Conexión inalámbrica (opcional)
- Pellet alimentado



- Combustion modulée
- Panneau de commande numérique et menu turc
- Allumage automatique
- Four de nettoyage entièrement automatique
- Système de nettoyage manuel du turbulateur
- Système de nettoyage automatique du turbulateur (ort.)
- Ventilateur d'extraction
- Programmation hebdomadaire
- Connexion du thermostat d'ambiance
- Protection contre le contre-jour
- Système de chauffage
- échangeur d'eau chaude (en option)
- Wi-Fi - connexion sans fil (facultatif)
- Granulés alimentés



- модулированное сгорание
- Цифровая панель управления
- автоматическое зажигание
- Полностью автоматическая очистка печи
- Ручная система очистки турбулизатора
- Автоматическая система очистки турбулизатора (опция)
- Вытяжка
- Еженедельное программирование
- Подключение комнатного термостата
- Подсветка защиты
- Система обогрева
- Теплообменник горячей воды (опция)
- Wi-Fi - беспроводное соединение (опция)
- Пеллет заправляется



- Combustione modulata
- Pannello di controllo digitale
- Accensione automatica
- Forno per la pulizia completamente automatico
- Sistema di pulizia manuale del turbolatore
- Sistema automatico di pulizia del turbolatore (opzionale)
- Extractor fan
- Programmazione settimanale Chrono
- Connessione del termostato ambiente
- Protezione contro luce
- Sistema di riscaldamento
- Scambiatore di acqua calda (opzionale)
- Wi-Fi - Connessione wireless (opzionale)
- Combustibile a pellet

 15 - 4,5 kW	 15 kW	 91,53 - 91,64 %	 3,5 - 1,05 kg / h
 40 - 67 kg - lt	 231 kg	 Ø 100 mm	

Green



IFYIL

www.ifyil.com.tr

GT 25

PELLET BOILER

PELLET SYSTEM
STYLISH DESIGN
MODERN HEATING
SOLUTIONS...

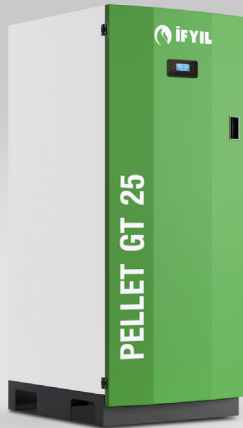

A⁺

EN 303-5 / Class 5
DM186 / Class 4

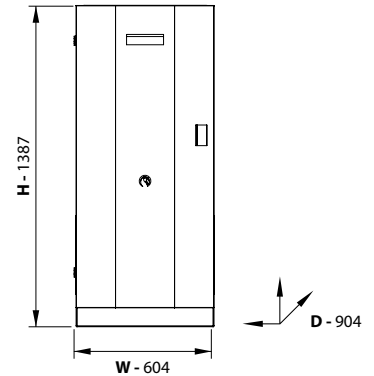

EN 303-5



BAFA
Bundesamt für Wirtschaft
und Ausfuhrkontrolle

BImSchV 2



CONTO TERMICO 2.0



- Modulated combustion
- Digital control panel
- Automatic ignition
- Fully automatic cleaning furnace
- Manual turbulator cleaning system
- Auto - turbo clean system (opt)
- Extractor Fan
- Chorono (Weekly Programing)
- Room thermostat connection
- BackFlame protection
- Heating system
- Hot water exchanger (optional)
- Wi-Fi - Wireless connection (optional)
- Pellet fueled



- Modulierende Verbrennung
- Digitales Bedienfeld
- Automatische Zündung
- Vollautomatischer Reinigungssofen
- Manuelles Turbulatorreinigungssystem
- Automatisches Turbulatorreinigungssystem (opt.)
- Abzugsventilator
- Wöchentliche Programmierung Chorono
- Raumthermostatanschluss
- Zurück Flammenschutz
- Heizungssystem
- Warmwassertauscher (optional)
- Wi-Fi - kabellose Verbindung (optional)
- Pellets befeuert



- Combustion modulée
- Panneau de commande numérique et menu turc
- Allumage automatique
- Four de nettoyage entièrement automatique
- Système de nettoyage manuel du turbulateur
- Système de nettoyage automatique du turbulateur (ort.)
- Ventilateur d'extraction
- Programmation hebdomadaire
- Connexion du thermostat d'ambiance
- Protection contre le contre-jour
- Système de chauffage
- échangeur d'eau chaude (en option)
- Wi-Fi - connexion sans fil (facultatif)
- Granulés alimentés



- Combustione modulata
- Pannello di controllo digitale
- Accensione automatica
- Forno per la pulizia completamente automatico
- Sistema di pulizia manuale del turbolatore
- Sistema automatico di pulizia del turbolatore (opzionale)
- Extractor fan
- Programmazione settimanale Chrono
- Connessione del termostato ambiente
- Protezione contro luce
- Sistema di riscaldamento
- Scambiatore di acqua calda (opzionale)
- Wi-Fi - Connessione wireless (opzionale)
- Combustibile a pellet



- Combustión modulada
- Panel de control digital y menú turco.
- Encendido automático
- Horno de limpieza totalmente automático.
- Sistema de limpieza manual del turbulador.
- Sistema automático de limpieza del turbulador (opc)
- Ventilador extractor
- Programación semanal
- Conexión de termostato de habitación.
- Protección de contraluz
- Sistema de calefacción
- Intercambiador de agua caliente (opcional)
- Wi-Fi - Conexión inalámbrica (opcional)
- Pellet alimentado



- модулированное сгорание
- Цифровая панель управления
- автоматическое зажигание
- Полностью автоматическая очистка печи
- Ручная система очистки турбулизатора
- Автоматическая система очистки турбулизатора (опция)
- Вытяжка
- Еженедельное программирование
- Подключение комнатного термостата
- Подсветка защиты
- Система обогрева
- Теплообменник горячей воды (опция)
- Wi-Fi - беспроводное соединение (опция)
- Пеллет заправляется

 25 - 7,5 kW	 25 kW	 91,7 - 92,4 %	 5,7 - 1,7 kg / h
 50 - 83 kg - lt	 280 kg	 Ø 100 mm	

Green



IFYIL

www.ifyil.com.tr

GT 40

PELLET BOILER

PELLET SYSTEM
 STYLISH DESIGN
 MODERN HEATING
 SOLUTIONS...



A⁺

EN 303-5 / Class 5
DM186 / Class 4

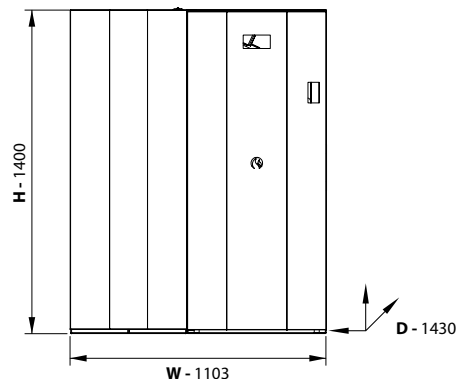

EN 303-5



BAFA
 Bundesamt für Wirtschaft
 und Ausfuhrkontrolle

BImSchV 2



CONTO TERMICO 2.0



- Modulated combustion
- Digital control panel
- Automatic ignition
- Fully automatic cleaning furnace
- Manual turbulator cleaning system
- Auto - turbo clean system (opt)
- Extractor Fan
- Chorono (Weekly Programing)
- Room thermostat connection
- BackFlame protection
- Heating system
- Hot water exchanger (optional)
- Wi-Fi - Wireless connection (optional)
- Pellet fueled



- Modulierende Verbrennung
- Digitales Bedienfeld
- Automatische Zündung
- Vollautomatischer Reinigungssofen
- Manuelles Turbulatorreinigungssystem
- Automatisches Turbulatorreinigungssystem (opt.)
- Abzugsventilator
- Wöchentliche Programmierung Chorono
- Raumthermostatanschluss
- Zurück Flammenschutz
- Heizungssystem
- Warmwassertauscher (optional)
- Wi-Fi - kabellose Verbindung (optional)
- Pellets befeuert



- Combustión modulada
- Panel de control digital y menú turco.
- Encendido automático
- Horno de limpieza totalmente automático.
- Sistema de limpieza manual del turbulador.
- Sistema automático de limpieza del turbulador (opc)
- Ventilador extractor
- Programación semanal
- Conexión de termostato de habitación.
- Protección de contraluz
- Sistema de calefacción
- Intercambiador de agua caliente (opcional)
- Wi-Fi - Conexión inalámbrica (opcional)
- Pellet alimentado



- Combustion modulée
- Panneau de commande numérique et menu turc
- Allumage automatique
- Four de nettoyage entièrement automatique
- Système de nettoyage manuel du turbulateur
- Système de nettoyage automatique du turbulateur (ort.)
- Ventilateur d'extraction
- Programmation hebdomadaire
- Connexion du thermostat d'ambiance
- Protection contre le contre-jour
- Système de chauffage
- échangeur d'eau chaude (en option)
- Wi-Fi - connexion sans fil (facultatif)
- Granulés alimentés



- модулированное сгорание
- Цифровая панель управления
- автоматическое зажигание
- Полностью автоматическая очистка печи
- Ручная система очистки турбулизатора
- Автоматическая система очистки турбулизатора (опция)
- Вытяжка
- Еженедельное программирование
- Подключение комнатного термостата
- Подсветка защиты
- Система обогрева
- Теплообменник горячей воды (опция)
- Wi-Fi - беспроводное соединение (опция)
- Пеллет заправляется



- Combustione modulata
- Pannello di controllo digitale
- Accensione automatica
- Forno per la pulizia completamente automatico
- Sistema di pulizia manuale del turbolatore
- Sistema automatico di pulizia del turbolatore (opzionale)
- Extractor fan
- Programmazione settimanale Chrono
- Connessione del termostato ambiente
- Protezione controluze
- Sistema di riscaldamento
- Scambiatore di acqua calda (opzionale)
- Wi-Fi - Connessione wireless (opzionale)
- Combustibile a pellet

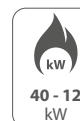

40 - 12 kW

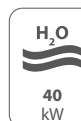

40 kW

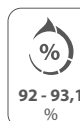

92 - 93,1 %



9,35 - 2,7 kg / h



253 - 420 kg - lt



310 + 100 kg



Ø 130 mm

Green



IFYIL

www.ifyil.com.tr

GT 60

PELLET BOILER

PELLET SYSTEM
STYLISH DESIGN
MODERN HEATING
SOLUTIONS...



A⁺

EN 303-5 / Class 5
DM186 / Class 4

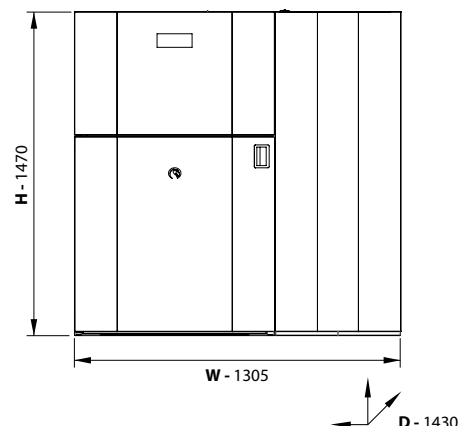

EN 303-5



BAFA
Bundesamt für Wirtschaft
und Ausfuhrkontrolle

BImSchV 2



CONTO TERMICO 2.0



- Modulated combustion
- Digital control panel
- Automatic ignition
- Fully automatic cleaning furnace
- Manual turbulator cleaning system
- Auto - turbo clean system (opt)
- Extractor Fan
- Chorono (Weekly Programing)
- Room thermostat connection
- BackFlame protection
- Heating system
- Hot water exchanger (optional)
- Wi-Fi - Wireless connection (optional)
- Pellet fueled



- Modulierende Verbrennung
- Digitales Bedienfeld
- Automatische Zündung
- Vollautomatischer Reinigungssofen
- Manuelles Turbulatorreinigungssystem
- Automatisches Turbulatorreinigungssystem (opt.)
- Abzugsventilator
- Wöchentliche Programmierung Chorono
- Raumthermostatanschluss
- Zurück Flammenschutz
- Heizungssystem
- Warmwassertauscher (optional)
- Wi-Fi - kabellose Verbindung (optional)
- Pellets befeuert



- Combustión modulada
- Panel de control digital y menú turco.
- Encendido automático
- Horno de limpieza totalmente automático.
- Sistema de limpieza manual del turbulador.
- Sistema automático de limpieza del turbulador (opc)
- Ventilador extractor
- Programación semanal
- Conexión de termostato de habitación.
- Protección de contraluz
- Sistema de calefacción
- Intercambiador de agua caliente (opcional)
- Wi-Fi - Conexión inalámbrica (opcional)
- Pellet alimentado



- Combustion modulée
- Panneau de commande numérique et menu turc
- Allumage automatique
- Four de nettoyage entièrement automatique
- Système de nettoyage manuel du turbulateur
- Système de nettoyage automatique du turbulateur (ort.)
- Ventilateur d'extraction
- Programmation hebdomadaire
- Connexion du thermostat d'ambiance
- Protection contre le contre-jour
- Système de chauffage
- échangeur d'eau chaude (en option)
- Wi-Fi - connexion sans fil (facultatif)
- Granulés alimentés



- модулированное сгорание
- Цифровая панель управления
- автоматическое зажигание
- Полностью автоматическая очистка печи
- Ручная система очистки турбулизатора
- Автоматическая система очистки турбулизатора (опция)
- Вытяжка
- Ежедневное программирование
- Подключение комнатного термостата
- Подсветка защиты
- Система обогрева
- Теплообменник горячей воды (опция)
- Wi-Fi - беспроводное соединение (опция)
- Пеллет заправляется



- Combustione modulata
- Pannello di controllo digitale
- Accensione automatica
- Forno per la pulizia completamente automatico
- Sistema di pulizia manuale del turbolatore
- Sistema automatico di pulizia del turbolatore (opzionale)
- Extractor fan
- Programmazione settimanale Chrono
- Connessione del termostato ambiente
- Protezione controluca
- Sistema di riscaldamento
- Scambiatore di acqua calda (opzionale)
- Wi-Fi - Connessione wireless (opzionale)
- Combustibile a pellet

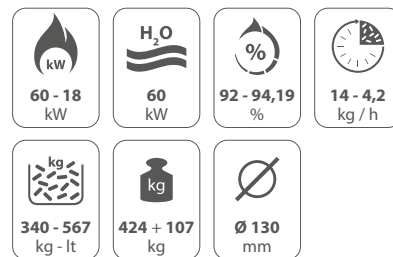

www.ifyil.com.tr